

# Acoustic Performance Guide

Insulated Roof, Wall & Facade Systems

*Insulated Panels  
to the Power of*



<b>Foreword</b>	4
<b>Guide Introduction</b>	5
<b>Testing Standards</b>	6
<b>Sound Insulation in Buildings</b>	7
<b>Reverberation and Sound Absorption:</b>	9
<b>Healthcare Buildings</b>	10
<b>Education Buildings</b>	11
<b>Office Buildings</b>	13
<b>Commercial, Retail &amp; Leisure Buildings</b>	14
<b>Industrial Buildings</b>	16
<b>Residential and Hotels</b>	19
<b>Rain Noise</b>	20
<b>Acoustic Test Results (Appendix A to E)</b>	22
<b>Construction Details (Appendix F)</b>	40
<b>Terminology (Appendix G)</b>	41
<b>References</b>	43

## Foreword

Kingspan has worked with Sound Research Laboratories (SRL) to compile a comprehensive set of acoustic test data, based on measured results, in an accredited Laboratory.

The guide reports performance information and practical advice on achieving the standards relevant to different building types. It is intended to be useful to the Acoustic Consultant and also to help Architects and Design Teams.

The guide also includes useful new advice on the control of rainfall noise. This is based on data from SRL's rainfall test rig.



## Guide Introduction

This guide gives the fundamentals of acoustics and how these apply to different categories of building. It demonstrates how the Kingspan range of Insulated Roof, Wall and Facade Systems can be used to help achieve acoustic requirements.

Most buildings need some form of acoustic control to meet various guidelines and statutory requirements. Kingspan panels offer external cladding solutions for roof and walls within the building. These provide acoustic control of the environment within the building giving:

- Sound insulation for the building envelope to control noise break-in to the building or noise breakout from the building.
- Effective flanking noise control, where internal partitions meet the building envelope.
- Acoustic absorption when used in conjunction with profiled perforated steel liners or absorbent suspended ceilings.
- Effective control of rain noise when used in conjunction with roof tiles, profiled perforated steel liners or absorbent suspended ceiling combinations.

Applications of Kingspan panels in terms of sound insulation, sound absorption and rain noise control are given for each classification of building type in this document.

The guide reports performance information with practical advice on achieving the standards relevant to different building types. It is intended to be useful to the Acoustic Consultant and also to help Architects and Design Teams.

The guide also includes useful new advice on the control of rainfall noise, based on data from SRL's rainfall test rig. Detailed flanking tests reveal the full potential of the products.

Details of laboratory test results are given in the Appendices, as follows:

### Appendix A

Sound insulation tests on Kingspan insulated wall and facade systems

### Appendix B

Sound insulation tests on Kingspan insulated roof systems

### Appendix C

Flanking sound insulation tests on Kingspan insulated roof, wall and facade systems

### Appendix D

Sound absorption tests on lined and unlined Kingspan insulated roof, wall and facade systems

### Appendix E

Rain noise tests on Kingspan roof systems

### Appendix F

Shows typical flanking construction

The assessments in this document have made various assumptions regarding room sizes, external noise spectra and installed internal partition performances. The advice is based on specific situations and cannot be used as general advice. Each project must be assessed on a case by case basis.

No account has been taken of any degradation of the noise flanking or noise break-in performances of the panels due to windows or other penetrations.

### Appendix G

Acoustic terminology used in this document are explained

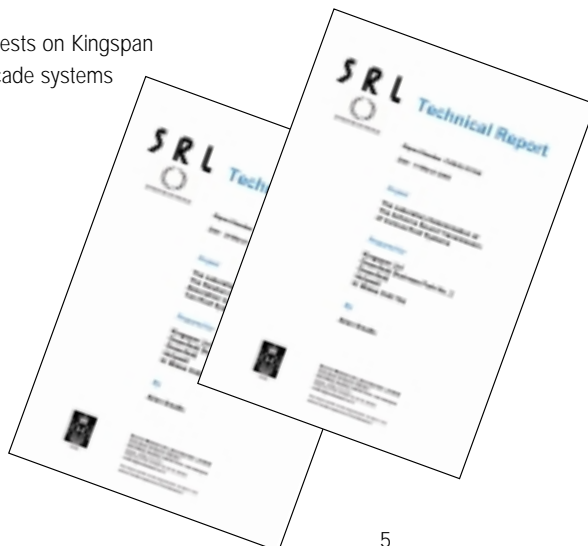

(((110 dB(A))))  
Typical nightclub noise level

## Testing and Standards

Tests were done in SRL's Laboratory in Suffolk, to determine the following;

- the random incidence sound absorption coefficients of wall systems in accordance with BS EN 20354:1993, ISO 354:1985.
- the airborne flanking sound transmission of various roof and wall systems with fire stop in accordance with BS EN ISO 140-3:1995.
- the sound reduction index of various roof systems in accordance with BS EN ISO 140-3:1995.
- the rain generated impact sound transmission of various roof systems in accordance with working draft International Standard ISO/CD 140-18.

Other test results referred to in this report include testing done by AIRO, BRE and Salford University. All tests conducted by SRL, excluding those done in the rain test rig, were UKAS accredited.

## Sound Insulation in Buildings

The sound insulation of a material is its ability to resist the passage of airborne and impact sound. From schools to hospitals and from dwellings to offices, sound insulation is important. It provides acoustic separation between rooms and between the outside world and the building interior.

All materials have different sound insulation properties that depend on their weight and physical build up. It is important to select the right material for the right application, and then construct the building to minimise weaknesses. Then the maximum sound insulation of the material can be realised. Often the degree of sound insulation achieved is limited by the paths that sound can travel to by-pass the material. This is called "flanking" and is shown as route B in Figure 1 on page 8.

The sound insulation needed is determined by industry guidelines and statutory requirements. Appropriate sound insulation for various building types is discussed in more detail in the sections which follow.

The Kingspan range of Insulated Roof, Wall and Facade Systems with appropriate internal linings and detailing can give high levels of sound insulation. Flanking around compartment/partition walls and intermediate floors can also be effectively controlled with the appropriate internal drylining solutions.

The results of laboratory sound insulation tests on Kingspan Insulated Roof, Wall and Facade Systems with various treatments are given in Appendices A and B respectively. Appendix C gives results of sound insulation tests using Kingspan Insulated Roof, Wall and Facade Systems as flanking constructions. The results apply to the thickness of materials tested, however, little variation was seen as a result of panel thickness increase or decrease.

The parameters used to describe sound insulation are different for each standard, and can be confusing. It is important they are not used interchangeably, as they do not mean the same thing. They include  $R_w$ ,  $D_w$ ,  $D_{nT,w}$ ,  $D_{nT,w} + C_w$ ,  $D_{nT,w(Tmf,max)}$ . These are standardised terms that take account of different conditions, and are described in more detail in the Terminology, Appendix G.

Rain noise on roofs is an aspect of sound insulation, against environmental sources, that is dealt with in a separate section in this document in more detail.

## Sound Insulation in Buildings Cont'd

The following diagrams show the various airborne sound transmission paths we need to consider.

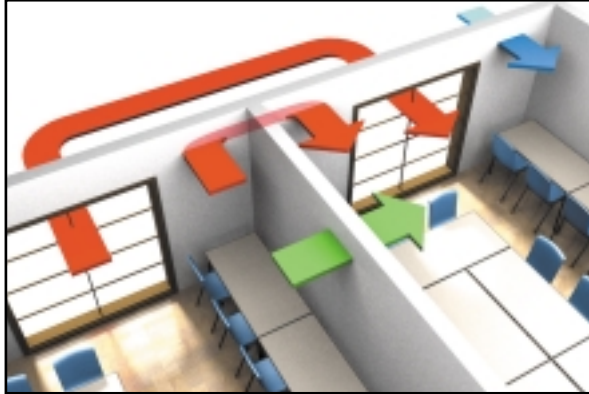

**Figure 1: Sound transmission paths**

- A = Direct route through partition between two rooms
- B = Noise flanking paths around ends of partitions and floors through joints and flanking constructions
- C = Direct route from outside through building external walls and roofs

External noise levels depend on the environmental noise sources in an area. Road traffic noise is a common source of noise which affects many buildings of all types in and around built up areas.

Maximum noise levels for short term events may also need to be taken into account. This depends on the building type and the relevant acoustic criteria.

Sound Pressure Level dB(A) re $2 \times 10^{-5}$ Pa	Typical Example	
140	Threshold of Pain	
130	Racing Engine Test Cell	
120	Jet Take Off at 50m	
100	Noisy Bottling Factory	
90	Pneumatic Drill in Operation at 3m	
85	Exposure limit for noise over 8 hours	
80	Inside Sports Car	
70	Raised Voice at 1m	

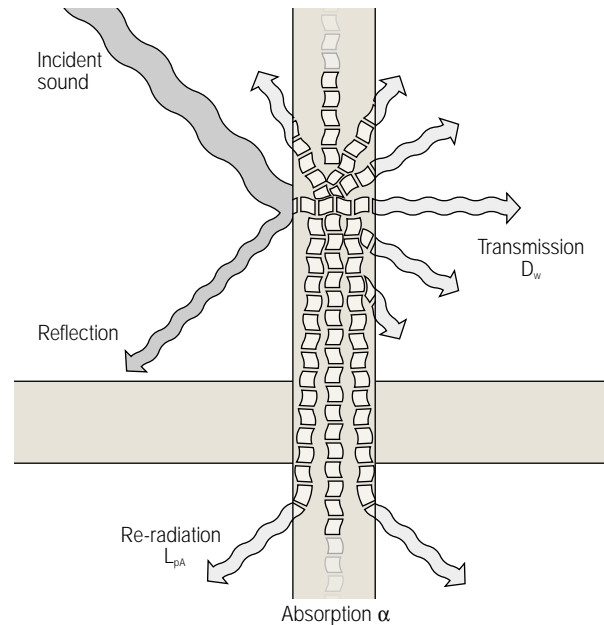

The correct noise insulation needs to be selected to achieve the break-in noise requirements for different building types. Often windows and other penetrations provide the weakest points in facades, but the overall performance needs to be assessed. This is dealt with in each specific section.

Sound Pressure Level dB(A) re $2 \times 10^{-5}$ Pa	Typical Example	
65	Heavy Rain on Metal Roof with Ceiling Tiles	
60	Normal Voice in Open Plan Office at 1m	
40-45	Private Office	
35-40	Residential Area at Night	
30	Whispering at 1m	
15-20	TV studio background	
0	Threshold of Hearing (Young People - 1KHz)	

## Reverberation and Sound Absorption

Sound absorption materials are often used in rooms to improve the perceived acoustic quality of the room and speech intelligibility. The materials are used to reduce the amount of noise which bounces around a room causing unwanted echoes. The study of these effects is commonly known as Room Acoustics.

### Sound Pressure Level in a Room

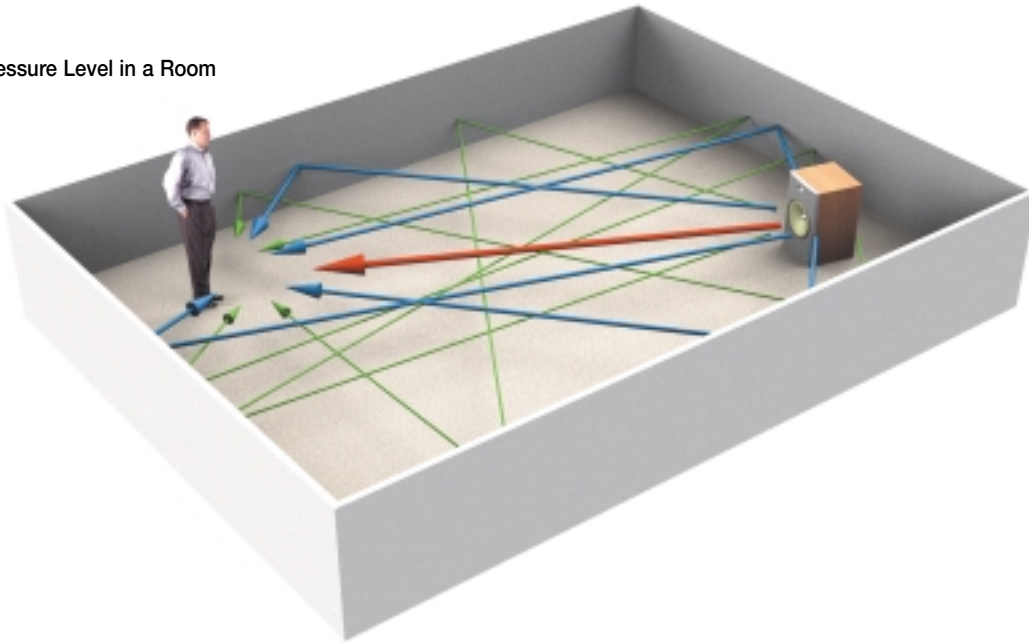

Figure 2 - Reverberation and the Sound Field in a Room

The way of objectively assessing the echoic nature of rooms is by measuring or predicting the reverberation time (often represented by RT or  $T_{60}$ ). This is defined as the time taken in seconds for a noise to decay in level by 60dB once it is turned off.

The reverberation in a room is controlled by using sound absorption, which is objectively expressed in terms of  $\alpha$ ,  $\alpha_w$ , NRC or absorption class. These are different ways of expressing the ratio of the amount of noise absorbed by a material to the total amount of noise incident on the material (See Appendix G for definitions).

The higher the absorption coefficient the more the absorption. An absorption coefficient of 1 means total absorption while an absorption coefficient of 0 means total reflection. Absorbers can also be defined by absorption classes, in line with EN ISO 11654. Class A are the best absorbers while Class E are the poorest, as shown in Figure 3 below.

It is a requirement in many buildings to meet specified reverberation times in different rooms, this is dealt with later in the guide. Materials providing absorption come in many forms ranging from soft wall panels, through mineral fibre ceiling tiles to perforated steel liners for profiled roof and wall applications with insulation behind. Appendix D gives absorption information for unperforated profiled liners in conjunction with the KS1000 RW panels and for the same panels with a 30% free area profiled perforated liner with 50mm insulation behind the perforations. The latter is classified as a Class A absorber, and provides a good alternative to ceiling tiles, and other finishes for reverberation control in many situations.

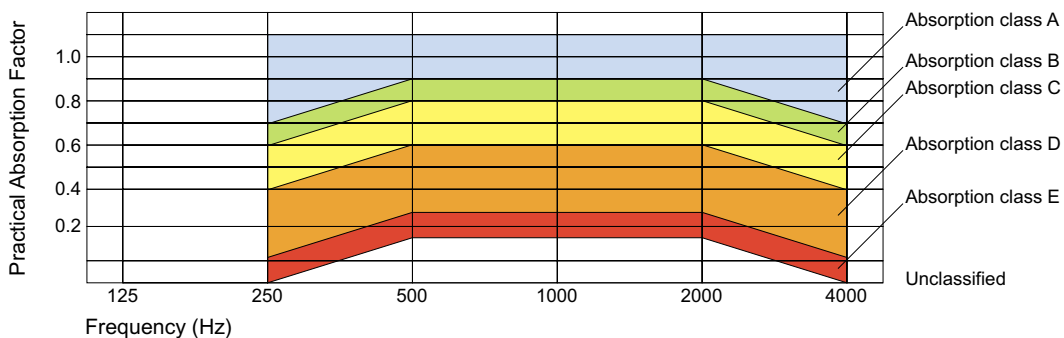
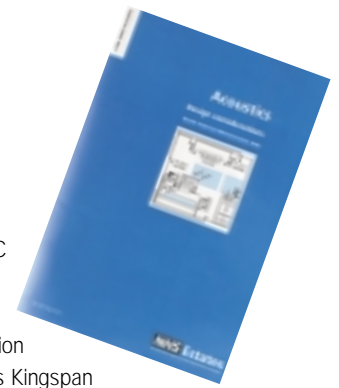

Figure 3: Absorption Classifications according to EN ISO 11654, with Class A providing the most absorption.



## Healthcare Buildings

NHS Estates Health Technical Memorandum HTM2045 deals with Acoustics in healthcare buildings, HTM2045 is currently under review although its contents are still relevant. It sets standards for noise break-in from external sources, sound insulation between different rooms and reverberation times. This is the recommended approach for achieving good acoustics for the finished building until the HTM is revised. To take account of non-acoustic constraints, derogations to HTM2045 are often sought. A practical outcome is that internal partitions in hospitals generally fall into 4 categories for sound insulation. To achieve these performances -

### The Typical Flanking Constructions are:

<b>Category A</b> $R_w$ 47 e.g. Toilets		5F*
<b>Category B</b> $R_w$ 52 e.g. Wards		9F*
<b>Category C</b> $R_w$ 57 e.g. Interview Rooms		9F*
<b>Category D</b> $R_w$ 62 e.g. Labour Delivery Room		6F*

In order to achieve the necessary site performance the flanking limits of the facade must be typically 5dB greater than these values in each case. \*The data in Appendix C (entries 5F, 6F and 9F) show that high flanking results can be achieved using any thickness of Kingspan panel system with plasterboard linings, as per the details shown in the figures in Appendix F.

For example, to achieve Category C performance requirements requires the flanking  $R_w$  to be 62dB. This could be achieved with a construction similar to 9F in Appendix C which is Kingspan 1000FL/70 panels internally lined with 12.5mm plasterboard on 'Z' channels. A Category D performance could be achieved by a construction similar to that described in 6F.

The requirement to internally line walls and roofs also provides effective acoustic control for noise break-in on all but the very noisiest sites.

The use of a perforated liner tray has been shown to provide excellent absorption that can be classified as a class A absorber. This rivals ceiling tiles as an option and can be useful when controlling reverberation time in hospital spaces (especially large circulation areas where other surfaces are often reflective to sound).





Hygiene requirements may require the mineral fibre to be bagged by a material that prevents fibre migration, and this may degrade the high frequency performance offered. It must be remembered that using a perforated liner tray that passes across the top of partitions (without careful design) will significantly reduce the sound insulation performance of the partition. Specialist advice should be sought to provide appropriate head detailing.

## Education Buildings

All new school buildings are now controlled under the requirements of the Building Regulations. The normal way of satisfying Requirement E4 of the Building Regulations Approved Document E 2003 Edition is to demonstrate that all the acoustic performance standards in DfES Building Bulletin 93 (BB93) have been met. These standards cover sound insulation between classrooms of different activity, noise break in, room acoustics and speech intelligibility. A requirement to consider rain noise is also contained, in Section 3 of BB93 and also dealt with on page 20 of this guide.

Internal partitions in schools generally fall into 5 categories for sound insulation. To achieve these performances -

### The Typical BB93 Flanking Constructions are:

<b>Category A</b> $R_w \leq 45$ e.g. Science laboratories		5F
<b>Category B</b> $R_w 50$ e.g. Classrooms		9F
<b>Category C</b> $R_w 55$ e.g. Dance studio		6F
<b>Category D</b> $R_w 60$ e.g. Music practice		6F*
<b>Category E</b> $R_w 65$ e.g. Music recital		6F*

\* See notes on right

In order to achieve the necessary site performance the flanking limits of the facade must be typically 5dB greater than these values in each case, assuming a high quality of workmanship and approved detailing. The data in Appendix C (6F and 9F) show that high flanking results are achievable with Kingspan insulated roof, wall and facade systems. These performances can be maintained using any thickness panel lined with plasterboard as per the details shown in the figures in Appendix F.

*\*To achieve the higher performance categories D and E would require additional measures such as increasing the thickness of plasterboard and supporting the plasterboard independent of the panels.*

For example, Category C performance ( $R_w$  55dB) requirements can be achieved with a construction similar to 9F in Appendix C that is the Kingspan AWP/70 panels internally lined with 12.5mm plasterboard on 'C' channels.

The requirement to internally line walls and roof also provides effective noise control for noise break-in on all but the very noisiest sites.

The use of a profiled perforated steel liner has been shown to provide excellent absorption (classified as a class A absorber). This rivals ceiling tiles as an option and can be useful when controlling reverberation time in sports halls, all classroom types and corridors.

Using a profiled perforated steel liner that passes across the top of partitions (without careful design) will significantly reduce the sound insulation performance of the partition. Result 10F in Appendix C shows that  $R_w$  37dB is the flanking limit. Specialist advice should be sought to provide appropriate head detailing.

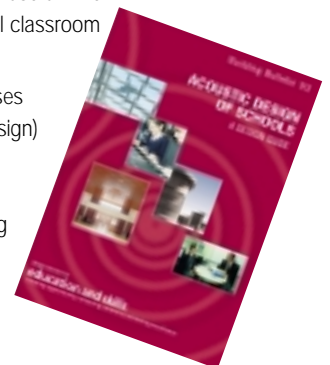

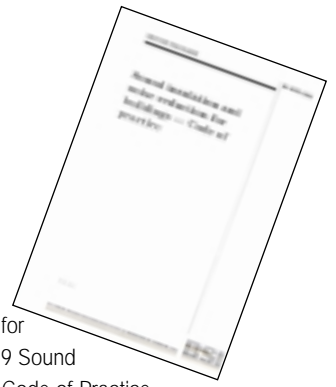

## Office Buildings

Guidance on acceptable acoustic standards for office Buildings can be found in BS8233:1999 Sound insulation and noise reduction for buildings - Code of Practice. British Council of Offices also provide guidelines, which do not differ greatly from BS8233. The external noise break-in criteria\* contribute to BREEAM assessments, and therefore can be crucial in gaining points. Issues to consider are:

- Privacy between offices, where a minimum of  $D_w$  38dB is suggested going up to a  $D_w$  of 48dB where privacy is important.
- \* Noise break-in from external sources where  $L_{Aeq}$  levels of between 35 and 45dB are considered to be appropriate, depending on the use.
- Control of reverberation will also help to control noise transfer and improve speech intelligibility. This is especially so in open plan offices, where ceilings with high absorption can be used.

In order to maintain the acoustic performance of internal partitions between offices, suitable flanking control has to be introduced. This is particularly so where the partition meets the external building envelope. In practice this means achieving the following typical flanking  $R_w$ 's.

### Typical Flanking Constructions

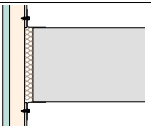
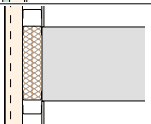
$D_w$ 38 Offices - $R_w$ 48		5F
$D_w$ 48 Offices - $R_w$ 58		9F

The  $D_w$  38dB office partition standard may be achieved using any panel with plasterboard lining with no air gap (see construction 5F in Appendix C). Normal installation usually has an air gap so in reality this is a minimum requirement to achieve the above.

The  $D_w$  48dB partition standard can be achieved with any panel that is lined with plasterboard as per the details (shown in the figures in Appendix F).

To control noise break-in, no lining is required for Kingspan insulated roof, wall and facade systems if external noise levels are  $L_{Aeq}$  55dB or less. Where external noise levels exceed  $L_{Aeq}$  55dB, an internal profiled steel liner or plasterboard lining is required. The exact specification depends on the external noise level.

In certain circumstances where external noise levels are less than 65dB  $L_{Aeq}$  it will be possible to use a panel with internal profiled perforated steel liner with 50mm insulation ( $60\text{kg/m}^3$ ) in the cavity to control noise break-in via the roof. This system provides high levels of sound absorption which will help control noise transfer across open plan offices.

5dB(A) )))  
 d noise in an office

## Commercial, Retail and Leisure Buildings

Some guidance on acoustic standards for commercial and retail developments can be found in BS8233:1999. 'Sound insulation and noise reduction for buildings' -Code of Practice. This gives suitable indoor ambient noise levels which range from 50 to 55dB  $L_{Aeq}$  for department stores.

This means that any Kingspan insulated roof, wall and facade systems can be used to control noise break-in to commercial or retail developments when the noise level outside is less than about 65dB  $L_{Aeq}$ . For higher external noise levels plasterboard or profiled steel liners may be required. Plasterboard linings will also control noise flanking around internal partitions through the external envelope.

The standard does not give advice on sound insulation between adjacent units in a retail development, although 40 to 45dB sound reduction is normally considered acceptable for normal retail uses. The performances of internal partitions can be achieved by limiting the flanking using any Kingspan insulated roof, wall and facade systems that is lined with plasterboard, as per the details shown shown in the figures in Appendix F.

Where higher levels of sound insulation are required between units, enhanced the flanking performance may be needed to sustain the performance of higher specification internal partitions and specialist advice should be sought.

Kingspan insulated roof, wall and facade systems can also be used for leisure schemes with the exact specifications depending on the activity and the tenant's requirements. These vary considerably and should be assessed on a project specific basis.



## Industrial Buildings

Most industrial buildings would not require any particular acoustic performance, unless there are significant sources of internal noise generated by the process. It is these specific examples of noisy internal working environments (e.g. bottling plants) that are discussed below.

### 1- External Noise break-in

Some guidance on acoustic standards for industrial units can be found in *BS8233:1999 'Sound Insulation and noise reduction for buildings' - Code of Practice*. This gives suitable indoor ambient noise levels of 65dB  $L_{Aeq}$  being a good standard.

This means that any Kingspan insulated roof, wall and facade systems would be suitable for the building envelope except for exceptionally noisy sites with external noise levels above 75 to 80dB  $L_{Aeq}$ . However this would be an unusual situation and noise break-out to the environment is normally of greater concern.

Lining the Kingspan insulated roof, wall and facade systems with plasterboard may be appropriate in offices associated with the industrial units to control noise flanking and maintain privacy. The same principles apply here as these given in the Section of the guide on offices.

### 2- Internal Noise and Break-out

The main guidance is in *BS 4142:1997 'Method for rating industrial noise affecting mixed residential and industrial areas'*. This standard provides an assessment method for the industrial noise. It takes into account the character of the noise, the relative background noise and the duration of the noise. It determines whether complaints about a noise are likely. BS 4142 is the standard widely accepted in the UK to determine the acceptability, or otherwise, of industrial noise.

The noise levels inside industrial units depend upon the power of the noise sources and the way in which the noise builds up by multiple reflections inside the building. (See 'Reverberation and Absorption' section). The higher the noise levels inside the building, the higher will be the break-out to outside. In addition, the noise break-out depends on the sound insulation of the surrounding facade and other weaknesses such as open doors, windows and ventilation routes.

To reduce the level of noise breaking out from an industrial unit, the noise should be reduced to as low a level as practicable at the source. This is achieved by buying quiet plant or machinery, by the application of noise control techniques to the plant or machinery and by control of reverberation.

The reverberation of industrial buildings can be controlled by making sure that the internal building surfaces have a high absorption coefficient. A Kingspan KS1000 RW panel with 50mm thick insulation inside a profiled perforated steel liner of 30% open area (See result 2A, Appendix D) is a Class A absorber. It has very high absorption coefficients across the frequency spectrum. Using this system will improve the internal noise climate for employees (see section on Noise at Work). This relates to reverberant noise only and not to direct noise which is experienced close to a source. However, due to their size, industrial buildings usually suffer a high proportion of reverberant noise.

In terms of noise break-out, any Kingspan panel will give about 25dB(A) sound reduction for typical industrial process noise (e.g. bottling plant). This can increase to typically 50dB(A) if the panels are lined with plasterboard. These are useful reductions which can be used to control noise break-out.

Most environmental industrial noise problems are caused by externally located plant, or break-out through open doors. However, tonal and impulsive internal noise can be problematic and each situation must be considered on a case by case basis (especially where the noise source contains high levels of low frequency noise). It is at low frequency where the sound insulation performance of Kingspan panels is relatively low.

### 3- Internal Noise Levels - Noise at Work

The ratified *Noise Control at Work Regulations 2006* stipulate that noise exposure levels for employees should be:

- Less than 80dB(A) for an 8 hour working day.
- If exposure is above this level, hearing protection should be worn.
- If the exposure per 8 hour working day is above 85dB(A), hearing protection must be worn.

There is also an obligation for employers to reduce noise levels generally in the workplace. The addition of the 50mm thick absorptive lining to Kingspan panels can reduce reverberant noise levels by 5 to 10dB(A). Thus it is possible to move a factory that is in the 'Compulsory Ear Protection' category where reverberant noise levels are above 85dB(A) (called the Upper Action value when exposure is for an 8 hour working day) to below the lower noise limit of 80dB(A) for an 8 hour working day (called the Lower Action Value) by using Kingspan panels, with an absorptive liner tray.

Correct treatment of an industrial building results in a building which is quieter to work in and is altogether more pleasant. Some particular benefits are:

- The PA system is more easily understood because of the elimination of echoes.
- Safety alarms are heard more easily.
- Conversation becomes easier.
- Noise caused by a faulty plant can be more readily identified; in a reverberant building it is difficult to detect the source of a particular noise.
- Free standing screens can be used to greater effect to control noise.



## Residential and Hotels

Residential buildings, Apartments, and Room for Residential Purposes (i.e. Hotels, Student Accommodation, Single Living Accommodation, but excluding Nursing Homes at present) must satisfy Approved Document E (2003 Edition) of the Building Regulations 2000.

The Building Regulations require certain standards of sound insulation between residential units. This can be demonstrated in two ways. The first is to build the construction using Robust Details. This is a set of approved details issued by Robust Details Ltd which have been tested and shown to be reliable in providing the required sound insulation. This approach means that the builder does not have to have constructions tested for sound insulation.

The second approach is to build the residential property using appropriate designs normally approved by an acoustic consultant and do Pre-Completion Tests (PCT) on about 10% of the party walls and floors between residential units.

The standards which have to be met to achieve Approved Document E, using PCT are as follows:

		$D_{nT,w} + C_{tr}$ dB
Purpose built dwelling - houses and flats	- walls	45
	- floors	45
Dwelling - houses and flats formed by material change of use	- walls	43
	- floors	43
Purpose built rooms for residential purposes	- walls	43
	- floors	45
Rooms for residential purposes formed by material change of use	- walls	43
	- floors	43

These standards can be achieved with Kingspan insulated roof, wall and facade systems as the external building envelope, provided they are internally lined with at least 1 layer of 12.5mm plasterboard using details similar to those shown in the figures in Appendix F. This assumes that suitable internal floor and partition constructions are used.

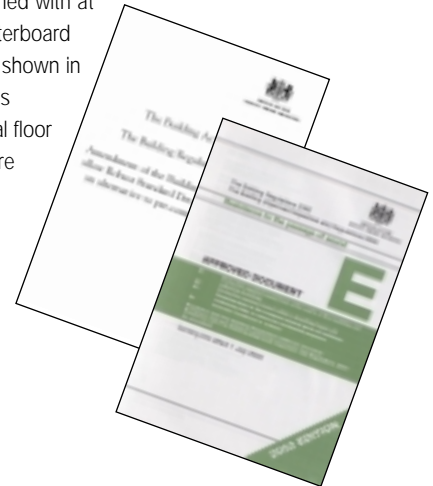



## Rain Noise

### When should Rain Noise be taken into account?

Rain noise should be taken into account at design stage where quiet conditions are essential, or where interference with speech communication is undesirable even for a short time (e.g. schools, call centres, some offices, cinemas etc). An acoustic consultant will be able to help determine whether careful attention to the control of rain noise is necessary or not.

The impact of rain on roof materials (particularly metal roofs) and the resulting internal noise created rain noise has been acknowledged as a potential problem in schools (in BB93). It should also be considered for other buildings such as hospital, residential, offices and leisure complexes.

Generally rain noise has been excluded from the standard classifications of environmental noise and the fact that it is transitory has led to little consideration over the years. However, BB93 requires that due consideration is given to the control of rain noise, either by external damping treatment or by enhancing the mass of the metal panels. The latter requires either internal mass layers or underscoring the roof panels with plasterboard or other material. BB93 suggests that either predicted results, but preferably laboratory measured results are needed, and reference is made to a draft measurement standard for impact sound from rain on the roof (ISO 140-18).

There is no actual limit that has to be achieved for rain noise, but levels as high as 70 to 80 dB  $L_{Aeq}$  can be caused inside spaces. This can have a dramatic effect on speech intelligibility. Kingspan insulated roof, wall and facade systems have tested in Sound Research Laboratories rain rig, to provide helpful information not previously available. The tests were done to ISO/CD 140-18, which is a working draft International Standard "Laboratory measurement of sound generated by rainfall on building elements", under "heavy" rainfall conditions. This is the standard referred to in BB93, but realistically these conditions are only likely to occur a few times a year in the UK.

The data is set out in Appendix E. The data enables rain noise levels to be predicted in any space where the room volume, reverberation time and roof area is known.

Appendix E also contains a worked example that demonstrates how this calculation can be done for a typical room. It provides a valuable tool to assess the impact of rain noise on the intended activities in a space. A judgement needs to be made on a case by case basis as to the acceptability of the noise.



Figure 4 : Sound Research Laboratories ISO 140-18 Rain Rig

# (((65dB(A))))

Typical rain on metal roof systems  
with ceiling tiles

## Rain Noise Solutions

Please refer to Appendix E for data and construction details.

### **Slates and KS1000 TS Roof System**

- The KS1000 TS system is based on an insulated roof panel which acts as a carrier for tiles fixed onto timber battens. The configuration tested comprised of an 80mm panel with roof tiles of 17kg/m<sup>2</sup>.

### **KS1000 RW roof systems with mineral fibre ceiling tiles**

- Use existing text but remove last sentence. Text in first sentence in brackets should read (19mm and 24mm tiles).

### **KS1000 RW roof system with perforated liner & 50mm mineral fibre**

- The base roof of a KS1000 RW 80mm was underdrawn with a profiled perforated steel liner (30% free area) containing 50mm thick mineral fibre (40-60 kg/m<sup>2</sup>).

These acoustic roof systems provide appropriate solutions for situations where rain noise is an issue.



## Acoustic Test Results Appendix A - Wall/Facade Panel Construction

Octave Band Sound Reduction Index (R) and Weighted Sound Reduction Index (R<sub>w</sub>)

Wall	Panel and Lining	Octave Band Sound Reduction Index R								R <sub>w</sub>	C <sub>v</sub>	Surface Weight Kg/m <sup>2</sup>
		63	125	250	500	1k	2k	4k	8k			
1W	AWP/60 + no lining	15	16	19	23	26	22	39	-	25	-3	18
2W	AWP/60 + F	12	19	32	42	50	52	60	-	43	-10	30
3W	AWP/60 + W15	14	17	31	40	48	46	56	-	41	-10	28
4W	AWP/60 + W15 + F	17	24	37	45	52	54	64	-	47	-9	40
5W	AWP/60 + P + W12	16	22	37	45	51	50	63	-	46	-10	41
6W	AWP/60 + P + W12	18	23	35	44	49	50	61	-	45	-8	41
7W	AWP/60 + I + P + W	18	24	37	48	53	55	63	-	48	-10	4
8W	KS1000 RW/40 + I + L	13	14	29	38	40	45	55	-	38	-9	20
9W	KS1000 RW/40 + I + L	12	16	30	40	44	51	64	-	40	-9	20
10W	AWP/70 + no lining	20	15	17	23	18	25	40	46	24	-4	12.5

### Key

AWP = Architectural Wall Panel with various profiles (Optimo, MR, EB, FL, MM, CX, WV, Longspan)

F = 10mm dense particle board (11.7kg/m<sup>2</sup>)

W15 = 15mm plasterboard (10kg/m<sup>2</sup>)

W12 = 12.5mm wallboard (7.9kg/m<sup>2</sup>)

P = 19mm dense plasterboard plank (15.2kg/m<sup>2</sup>)

I = Insulation (see construction description for details)

L = 0.7mm profiled steel liner sheet

The figures after the forward slash refers to the panel thickness in mm (ie AWP/60 = panel thickness of 60mm)

## Acoustic Test Results Appendix B - Roof Panel Construction

Octave Band Sound Reduction Index (R) and Weighted Sound Reduction Index (R<sub>w</sub>)

Roof	Panel and Lining	Octave Band Sound Reduction Index R								R <sub>w</sub>	C <sub>v</sub>	Surface Weight Kg/m <sup>2</sup>
		63	125	250	500	1k	2k	4k	8k			
1R	KS1000 LP/45 + I + 2 x SB	27	32	47	61	69	69	75	-	58	-11	-
2R	KS1000 RW/40 + I + L	8	17	32	43	48	54	60	-	43	-	2
3R	KS1000 RW/40 + I + L	11	19	36	48	54	61	73	-	46	-	19
4R	KS1000 RW/40 + I + Py	17	27	39	44	49	57	67	-	48	-	31
5R	KS1000 RW/30 + no lining	-	17	20	23	23	23	41	-	25	-3	-
6R	KS1000 RW/30 + I + L	-	18	35	50	55	59	60	-	44	-11	-
7R	KS1000 RW/50 + I + L	-	19	34	48	52	56	63	-	44	-10	-
8R	KS1000 RW/80 + I + L	-	20	36	48	50	66	70	-	46	-11	-
9R	KS1000 RW/80 + no lining	-	18	21	23	20	38	42	-	26	-4	-
10R	KS1000 RW/80 + no lining	20	18	20	24	20	29	39	47	25	-3	-
11R	KS1000 RW/80 + I + PL	18	19	22	29	31	40	58	49	32	-4	-
12R	KS1000 ZIP/90 + no lining	19	18	19	20	17	35	38	44	23	-4	-
13R	KS1000 LP/80 + no lining	19	19	19	22	19	35	39	46	24	-4	-
14R	KS1000 RT + no lining	20	19	21	22	22	32	38	44	25	-2	-
15R	KS1000 TS + no lining	20	16	15	23	29	39	45	53	27	-4	27

### Key

I = Insulation (see construction description for details)

2 x SB = 2 x 12.5mm dense plasterboard (15.2kg/m<sup>2</sup>)

L = Profiled Steel Liner Sheet

Py = 10mm thick dense particle board (11.7kg/m<sup>2</sup>)

PL = Profiled Perforated Steel Liner Sheet

The figures after the forward slash refers to the panel thickness in mm (ie LP/45 = panel thickness of 45mm)

## Acoustic Test Results Appendix C - Flanking Tests

Octave Band Sound Reduction Index (R) and Weighted Sound Reduction Index (R<sub>w</sub>)

Wall	Panel and Lining	Octave Band Sound Reduction Index R								R <sub>w</sub>	C <sub>r</sub>
		63	125	250	500	1k	2k	4k	8k		
1F	KS1000 RW/80 + no lining	14	30	35	40	35	45	54	57	40	-3
2F	KS1000 RW/80 + FSC	16	28	34	41	35	45	54	58	40	-4
3F	KS1000 RW/80 + FSC	17	29	37	44	36	46	55	62	42	-5
4F	KS1000 RW/80 + FSC	16	30	37	43	36	46	55	62	42	-5
5F	KS1000 RW/80 + FSC + Pb	28	34	41	46	52	62	62	68	51	-5
6F	KS1000 RW/80 + FSC + I + Pb1	29	39	50	58	64	66	63	68	60**(67)	-7
7F	AWP/70 + I	17	33	41	44	40	50	56	63	45	-4
8F	AWP/70 + I + PbM	19	34	43	46	41	50	57	64	47	-5
9F	AWP/70 + I + Pbz	32	36	49	57	63	66	63	69	59**(63)	-9
10F	KS1000 RW/80 + I + PL	21	21	24	34	52	58	57	56	37	-5

### Key

+ See construction description for details

\*\* Limited by performance of partition wall - Figures in brackets are calculated performances without the influence of partition wall.

FSC Fire Stop and Covers - Mineral fibre packing (60kg/m<sup>3</sup>) and 90 degree coverflashings with mastic beads at edges.,

AWP Architectural Wall Panel with various profiles (Optimo, MR, EB, FL, MM, CX, WV, Longspan)

The figures after the forward slash refers to the panel thickness in mm (ie RW/80 = panel thickness of 80mm)

Test walls were flanking a partition wall comprising 8 x 12.5mm standard wallboard each side of 50mm isolated timber studs with a 150mm cavity between inner layers of plasterboard containing 100mm of 45kg/m<sup>3</sup> mineral fibre insulation - estimated R<sub>w</sub> 61 dB.

## Acoustic Test Results Appendix D - Constructions for Absorption Test

Octave Band Sound Reduction Index (R) and Weighted Sound Reduction Index (R<sub>w</sub>)

Flanking Construction	Panel and Lining	Octave Band Sound Reduction Index R								NRC	α <sub>w</sub>	Class*
		63	125	250	500	1k	2k	4k	8k			
1A	KS1000 RW + no lining	0.07	0.25	0.20	0.10	0.15	0.10	0.08	0.15	0.10	0.15	E
2A	KS1000 RW panel + perf metal lining 30% free area + 50mm insulation 40/60 kg/m <sup>3</sup>	0.15	0.45	0.70	0.85	0.90	0.90	0.75	0.60	0.85	0.90	A

### Key

\* = Classification according to EN ISO 11654 (See Figure 3 for detail).

## Acoustic Test Results Appendix E - Rain Noise Tests

Octave Band Impact Sound Power Levels  $L_w$  and A- Weighted Sound Power Levels  $L_{WA}$

Ref No.	Panel and Lining	Octave Band Sound Reduction Index R								$L_{WA}$
		63	125	250	500	1k	2k	4k	8k	
*1RR	KS1000 RW/80 + T24	50	49	52	53	53	45	38	30	56
*2RR	KS1000 RW/80 + T19	50	49	52	54	54	47	37	29	57
*3RR	KS1000 RW/ 80 + I + PL	48	52	54	53	54	39	35	29	56
*4RR	KS1000 TS + 17kg/m <sup>2</sup> tiles	48	52	58	54	54	43	37	25	57

### Key

\* Rain flow rate 663ml/ minute with 3.5m drop height (heavy rain)

\*\* Rain flow rate 450 to 465 ml/ minute with 1m drop height

T24 = 24mm Mineral Fibre Tiles of 8.23kg/m<sup>2</sup> and Dncw 41dB

T19 = 19mm Mineral Fibre Tiles of 4.46kg/m<sup>2</sup> and Dncw 38dB

I = Mineral Fibre Insulation (60kg/m<sup>3</sup>),

PL = Profiled Perforated steel liner

The figures after the forward slash refers to the panel thickness in mm (ie RW/80 = panel thickness of 80mm)

### Worked Example of rain noise levels predicted inside a room, based on the above data

e.g. an office 5m long by 4m wide by 2.3m high has a KS1000 RW Kingspan roof with 24mm thick absorbent ceiling tiles hung beneath. (See construction 1RR in Appendix E). The reverberation time is 0.7 sec at all frequencies. Calculate the octave band sound pressure levels over the frequency range 63Hz to 8kHz and the A-weighted sound level.

The sound pressure level is calculated using the following equation:

$$L_{pr} = L_{Wref} + 10 \log T - 10 \log V + 14 + 10 \log S$$

Where  $L_{pr}$  is the rain noise sound pressure level in the room - dB

T is the reverberation time in the room - seconds

V is the volume of the room in m<sup>3</sup>

S is the room area m<sup>2</sup>

$L_{Wref}$  sound power level - (when 1m<sup>2</sup> of roof is excited) dB

$$L_{pr} = L_{Wref} + 10 \log (0.7) - 10 \log (46) + 14 + 10 \log (20)$$

$$L_{pr} = L_{Wref} - 1.5 - 16.5 + 14 + 13 = L_w + 9$$

	Octave Band Centre Frequency								
	63	125	250	200	1k	2k	4k	8k	Hz
$L_{Wref}$	50	49	52	53	53	45	38	30	dB
$L_{pr}$	59	58	61	62	62	54	47	39	dB
A- weighting	-25	-16	-9	-3	0	+1	+1	0	
Octave Band A- weighted Level	34	42	52	59	62	55	48	39	dB
<b>Overall A- weighted level = 65dB(A)</b>									

## Appendix A - Wall/Facade Panel Construction Details

1W - KS1000 AWP(60) - Insulated Wall Panel

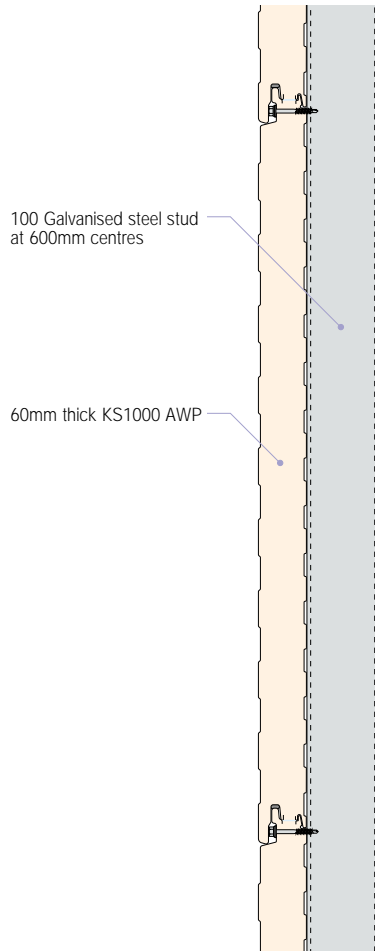

2W - KS1000 AWP(60) - Insulated Wall Panel

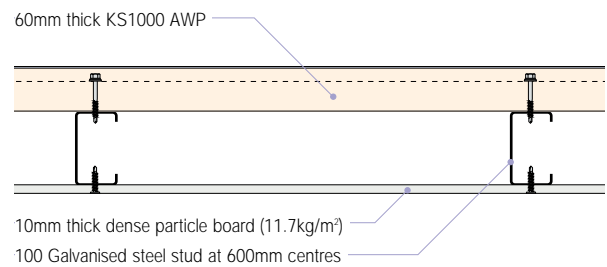
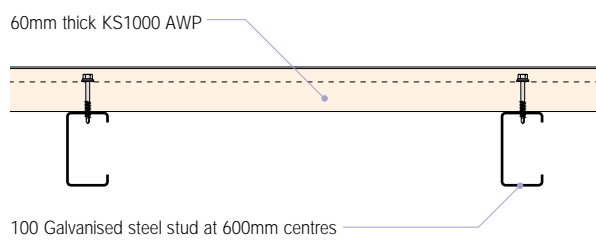
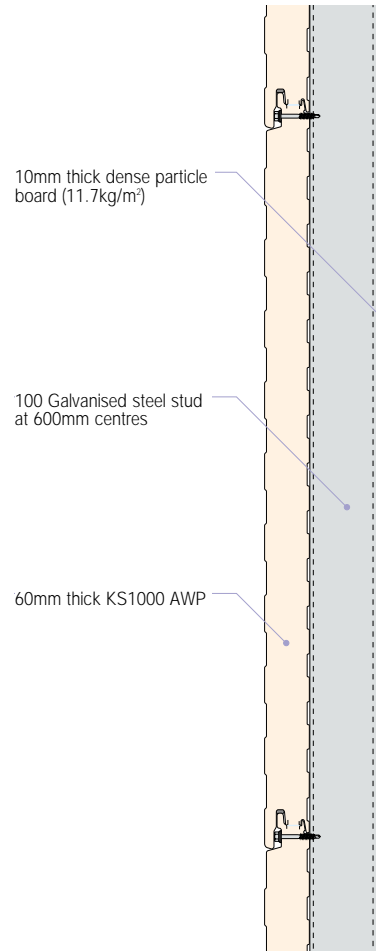

**3W - KS1000 AWP(60) - Insulated Wall Panel**

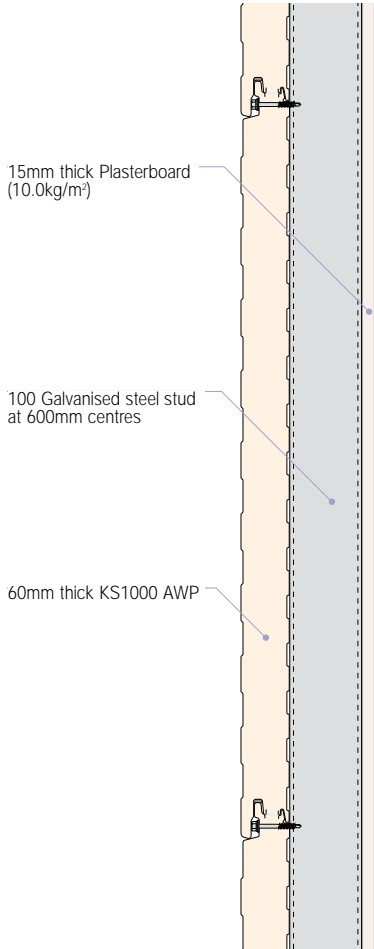

**4W - KS1000 AWP(60) - Insulated Wall Panel**

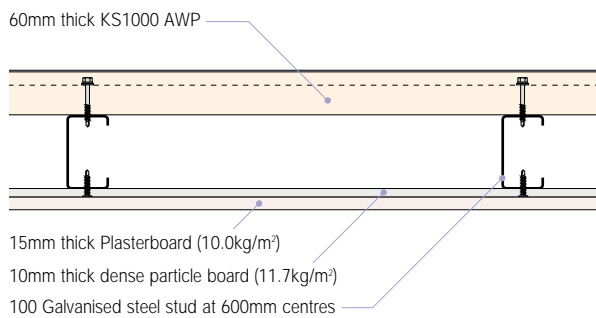
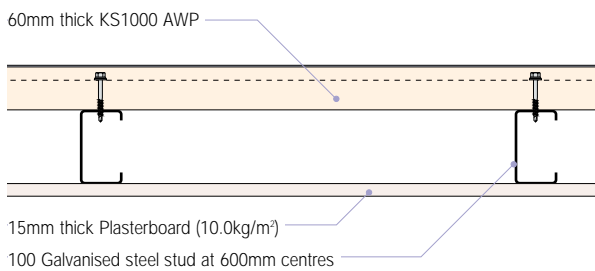
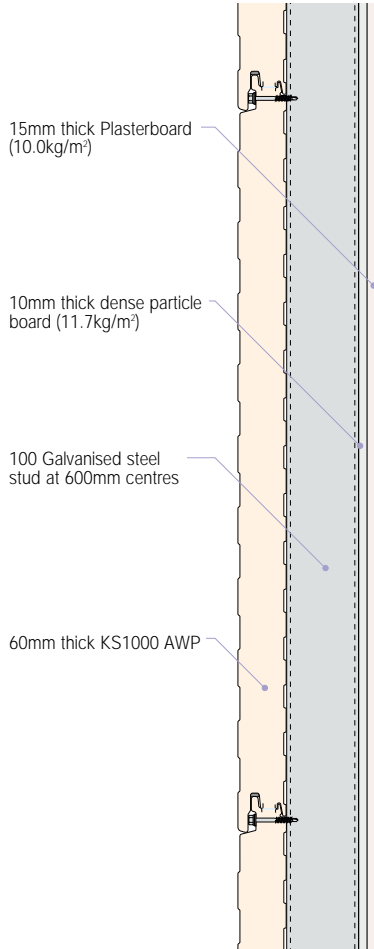

## Appendix A - Wall/Facade Panel Construction Details

5W - KS1000 AWP(60) - Insulated Wall Panel

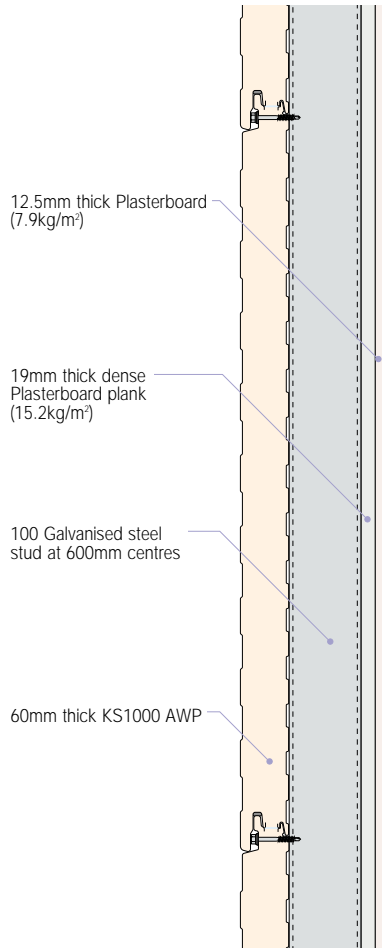

6W - KS1000 AWP(60) - Insulated Wall Panel

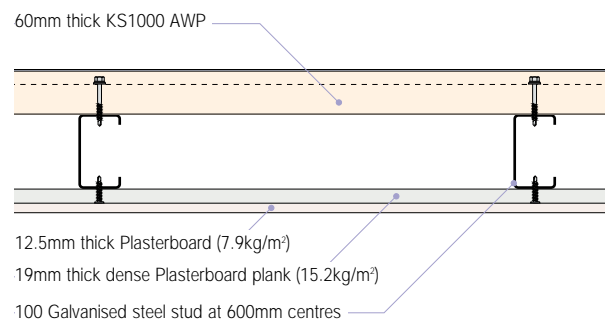
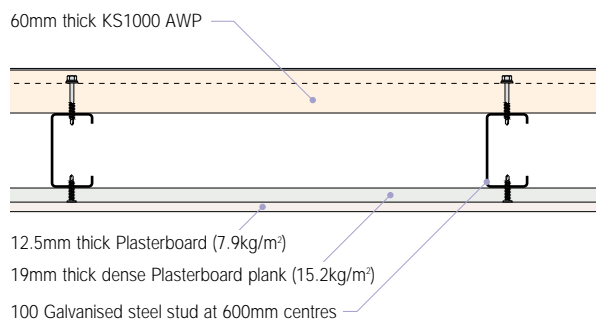
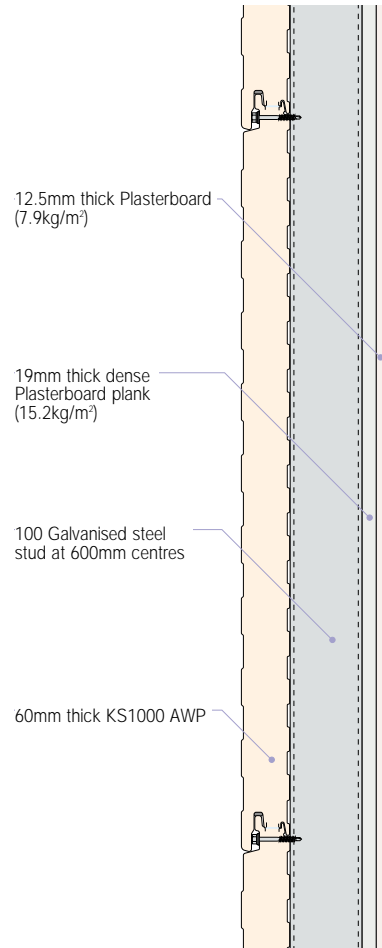

**7W - KS1000 AWP(60) - Insulated Wall Panel**

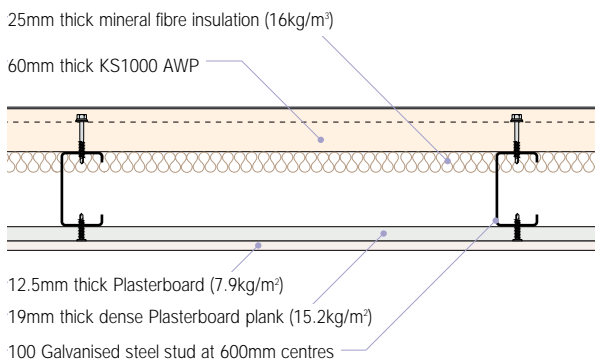
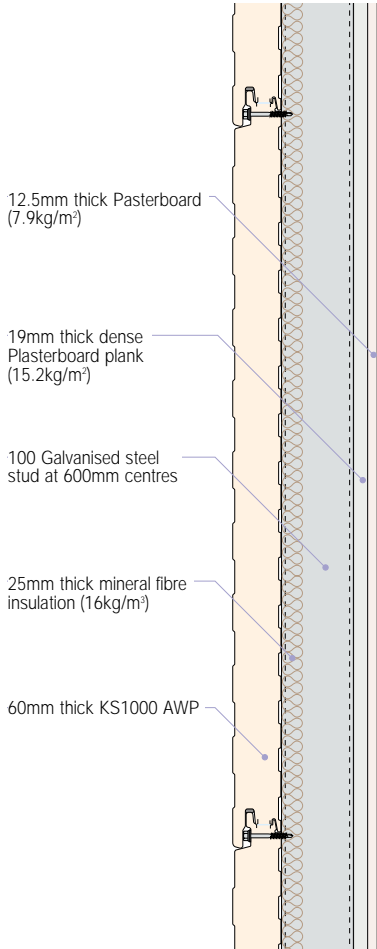

12.5mm thick Plasterboard (7.9kg/m<sup>2</sup>)  
 19mm thick dense Plasterboard plank (15.2kg/m<sup>2</sup>)  
 100 Galvanised steel stud at 600mm centres

**8W - KS1000 RW(40) - Insulated Trapezoidal Wall Panel**

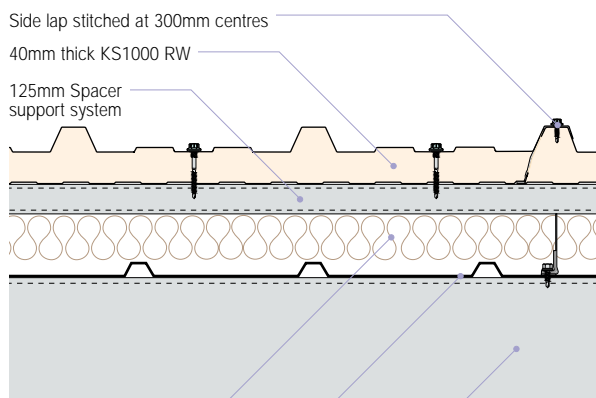
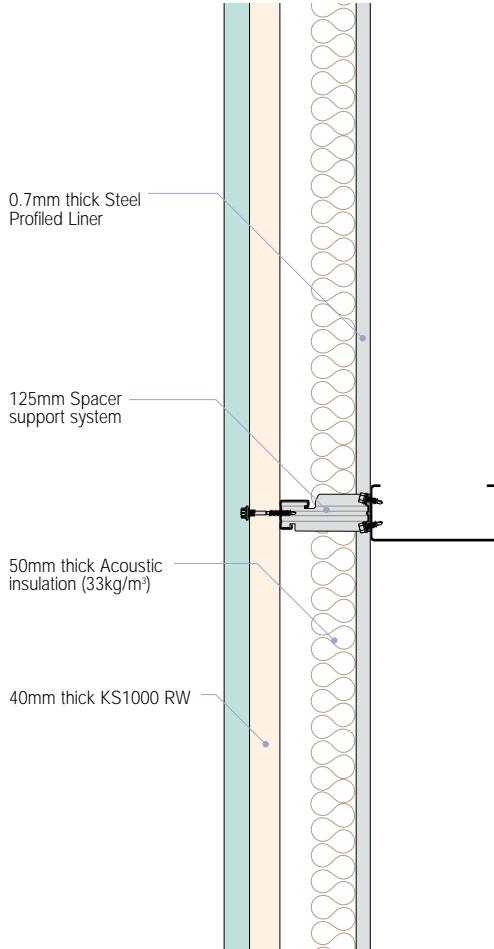

50mm thick Acoustic insulation (33kg/m<sup>3</sup>)  
 0.7mm thick Steel Profiled Liner  
 Multi channel at 2400mm centres

## Appendix A - Wall/Facade Panel Construction Details

9W - KS1000 RW(40) - Insulated Trapezoidal Wall Panel

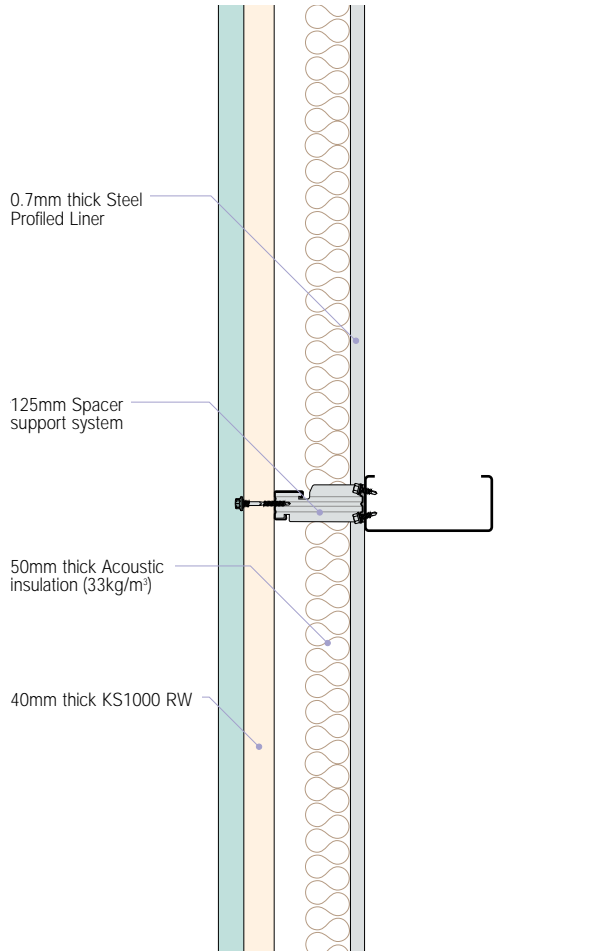

10W - KS1000 AWP(70) - Insulated Wall Panel

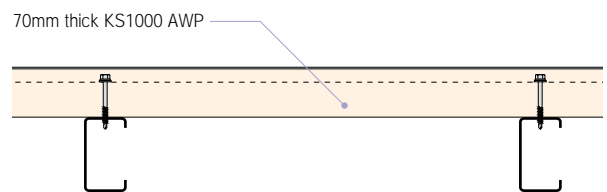
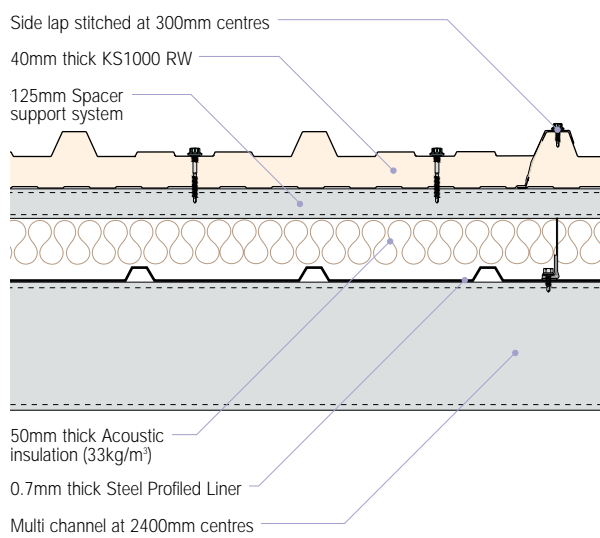
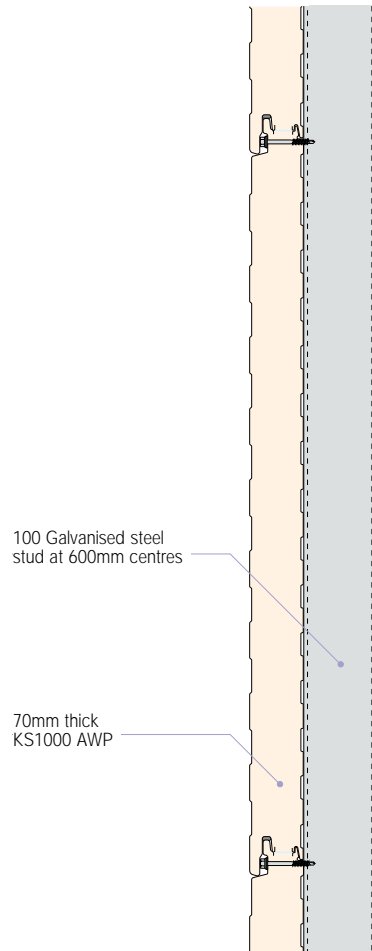

## Appendix B - Roof Panel Construction Details

### 1R - KS1000 LP (45) - Insulated Roof Panel

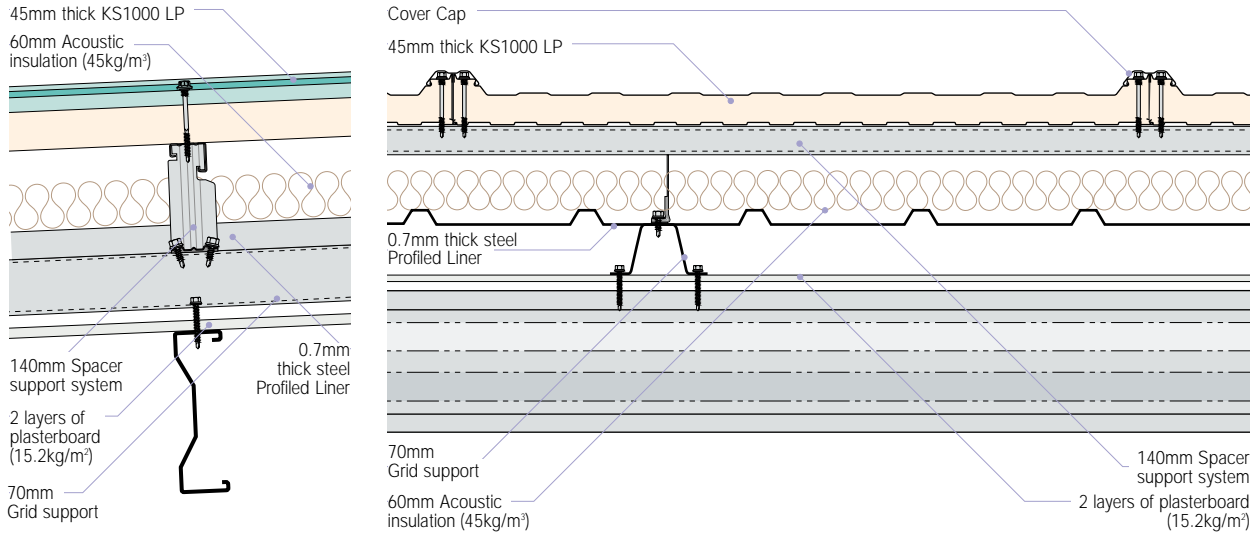

### 2R - KS1000 RW (40) - Insulated Roof Panel

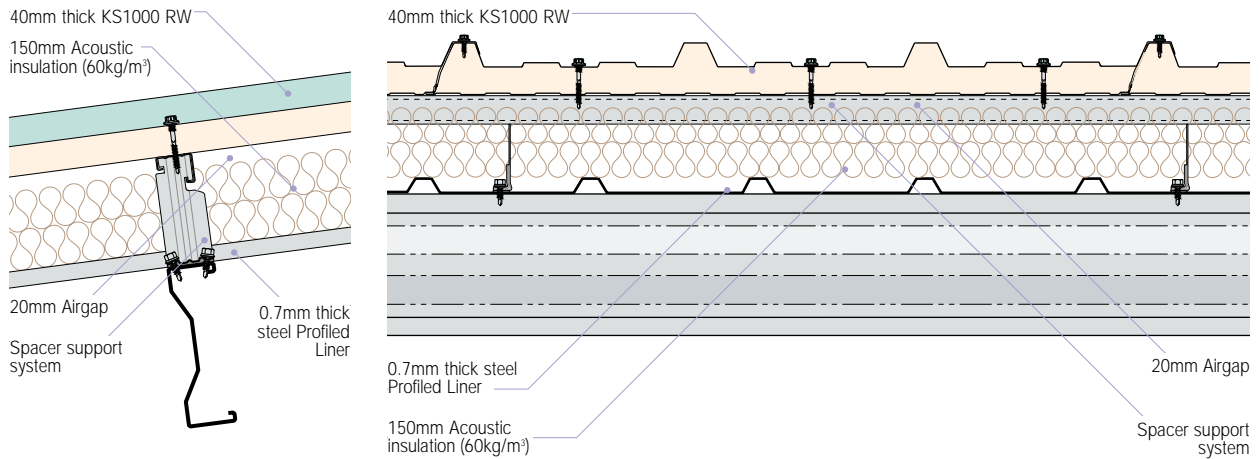

### 3R - KS1000 RW (40) - Insulated Roof Panel

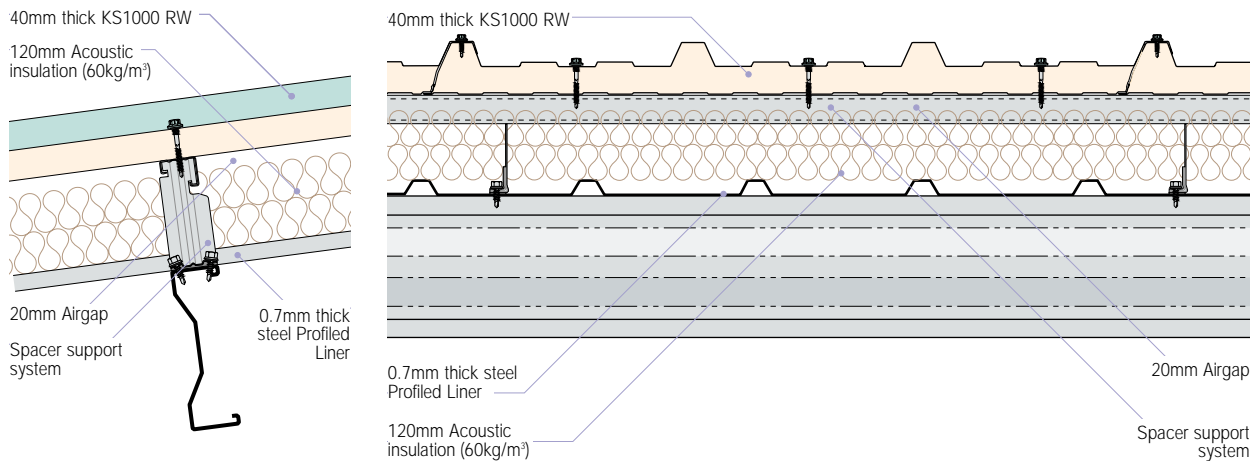

## Appendix B - Roof Panel Construction Details Cont'd

### 4R - KS1000 RW (40) - Insulated Roof Panel

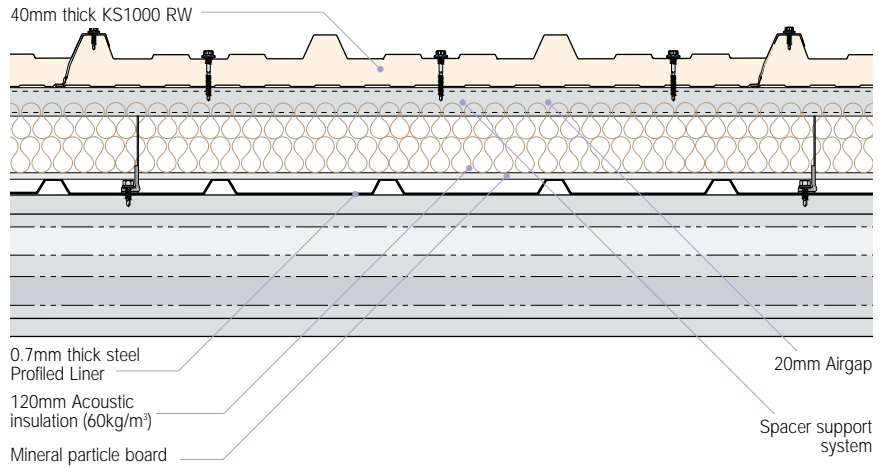
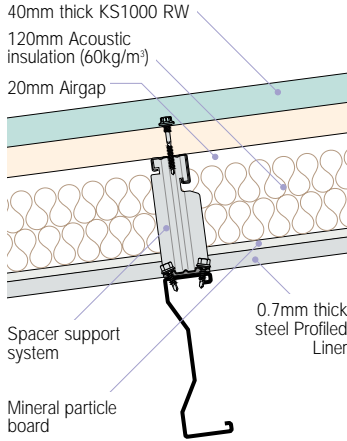

### 5R - KS1000 RW (30) - Insulated Roof Panel

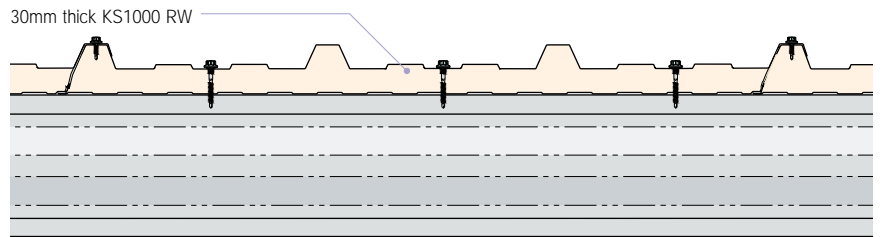
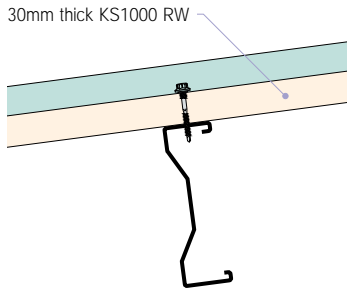

### 6R - KS1000 RW (30) - Insulated Roof Panel

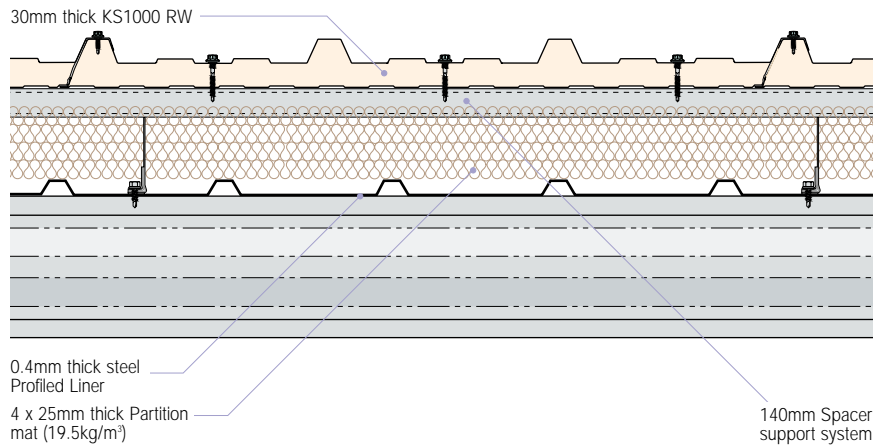
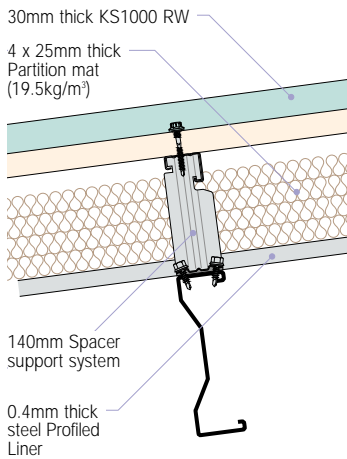

**7R - KS1000 RW (50) - Insulated Roof Panel**

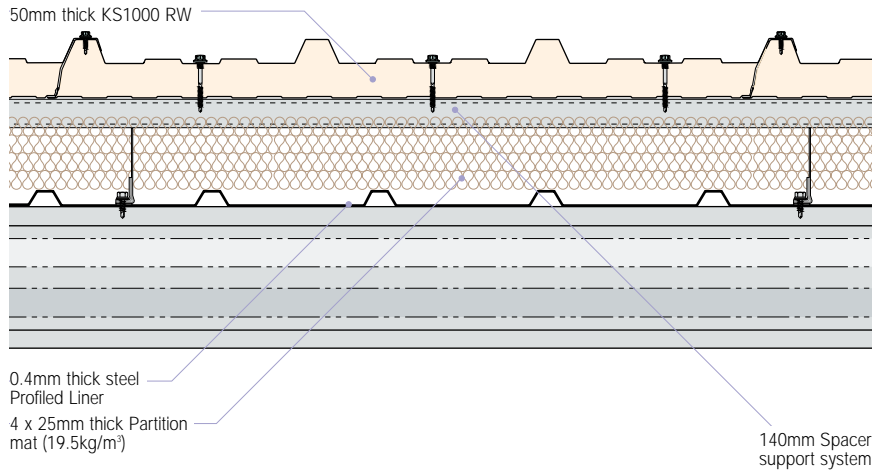
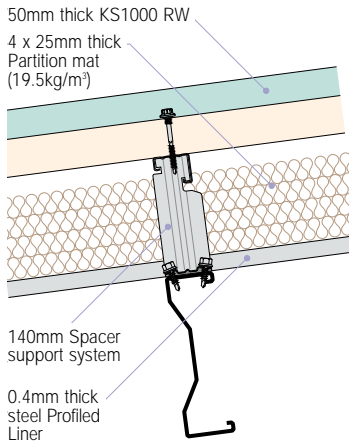

**8R - KS1000 RW (80) - Insulated Roof Panel**

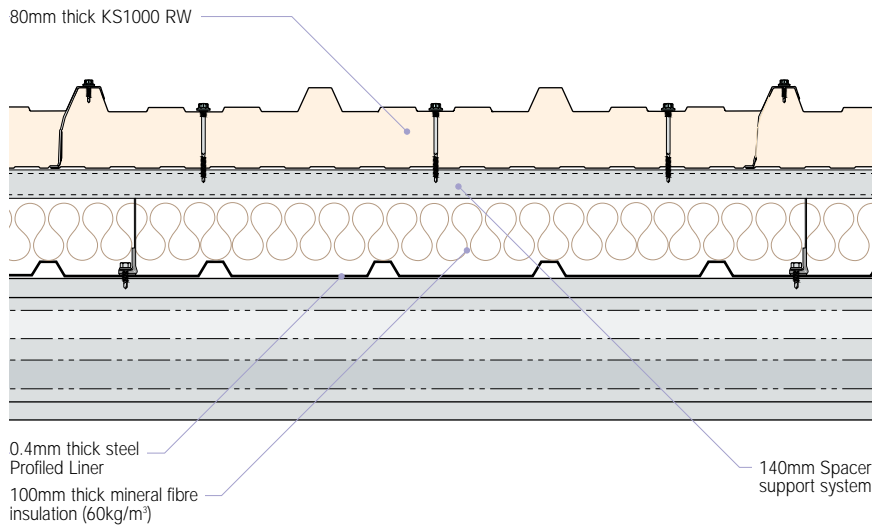
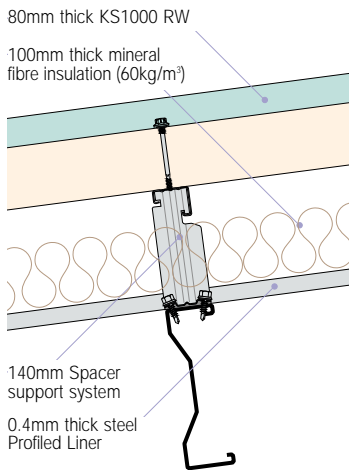

**9R - KS1000 RW (80) - Insulated Roof Panel**

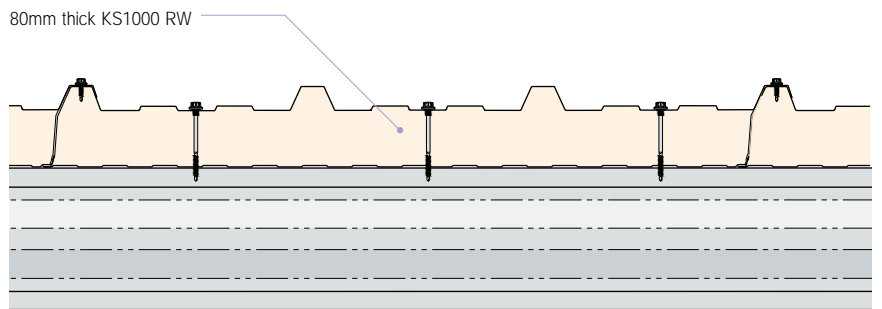
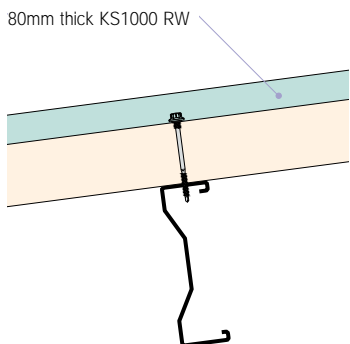

## Appendix B - Roof Panel Construction Details Cont'd

### 10R - KS1000 RW (80) - Insulated Roof Panel

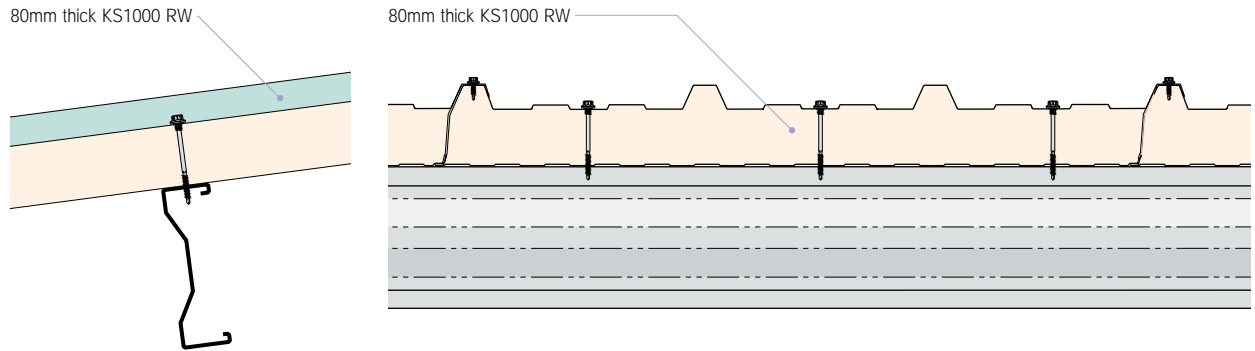

### 11R - KS1000 RW (80) - Insulated Rooftile Panel

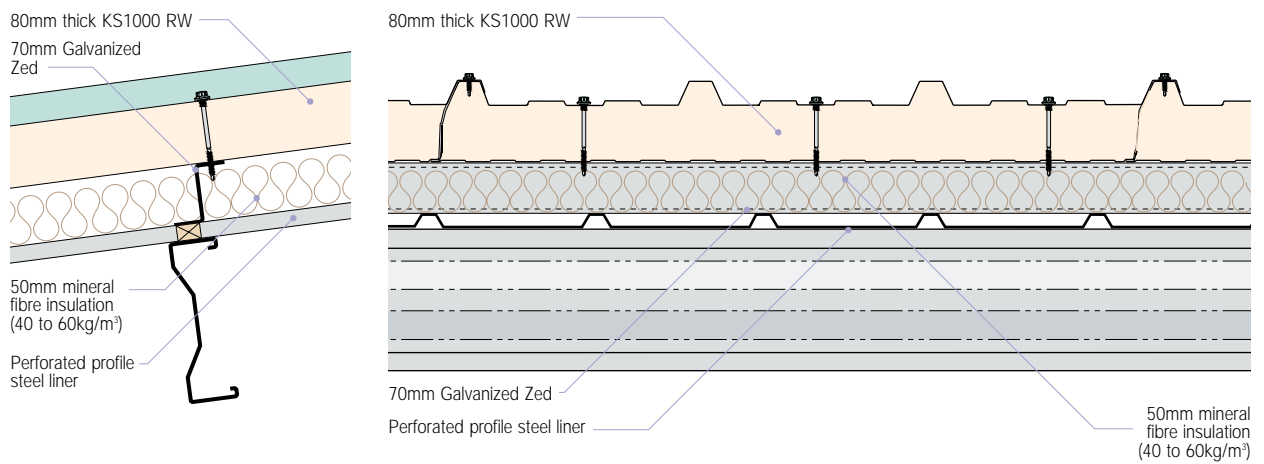

### 12R - KS1000 ZIP (90) - Insulated Standing Seam Roof Panel

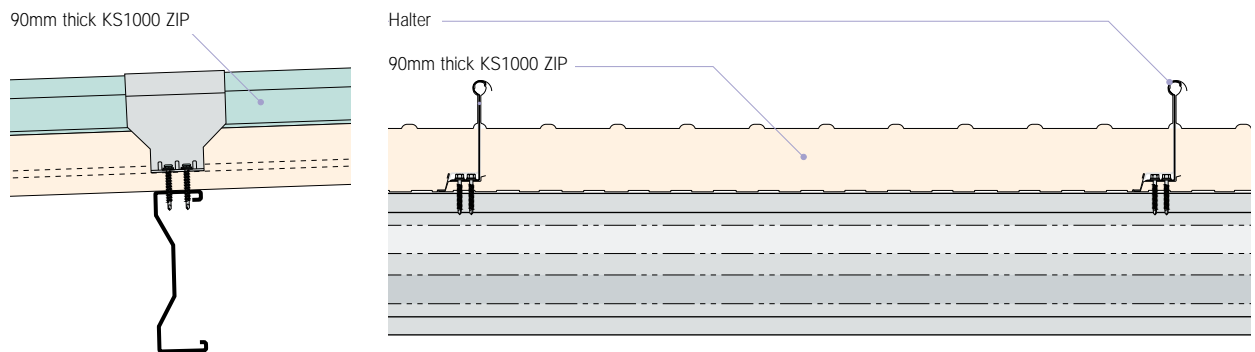

**13R - KS1000 LP (80) - Insulated Roof Panel**

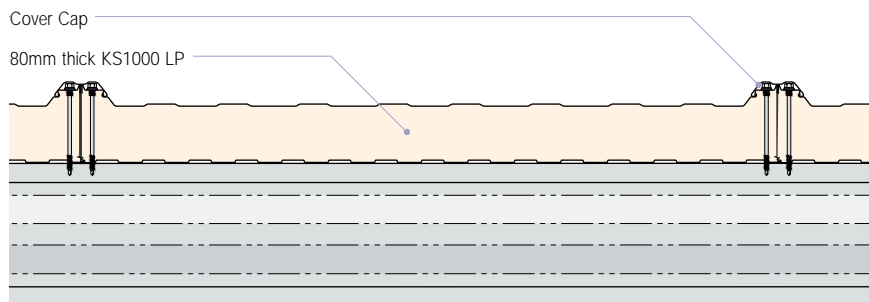
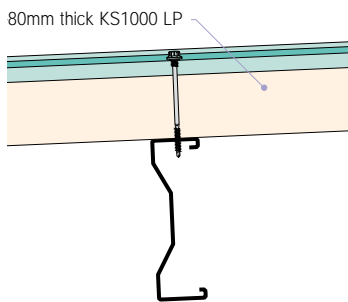

**14R - KS1000 RT (80) - Insulated Rooftile Panel**

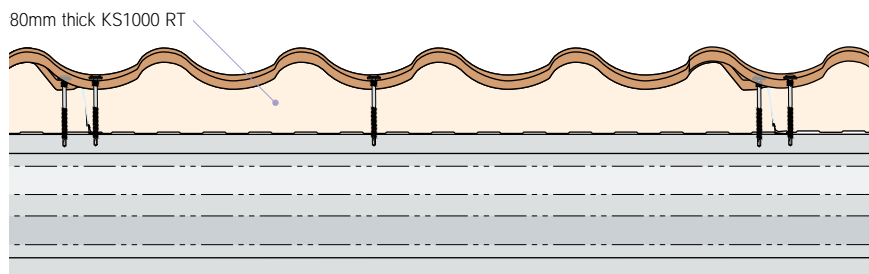
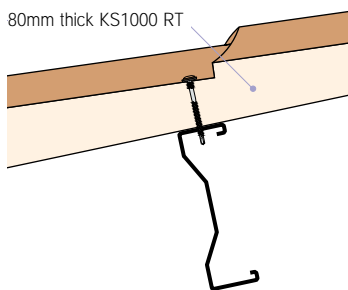

**15R - KS1000 TS (80) - Insulated Tile Support Panel**

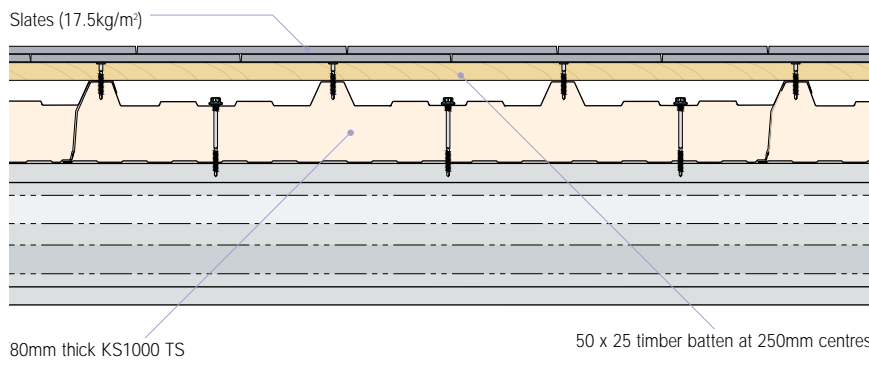
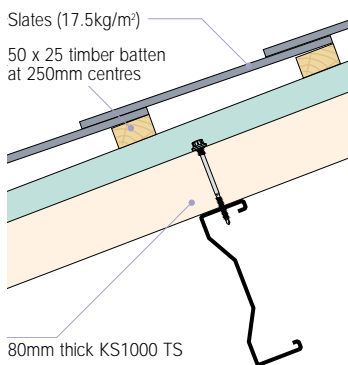

## Appendix C - Flanking Test Construction Details

1F - KS1000 RW Insulated Roof & Wall Panel

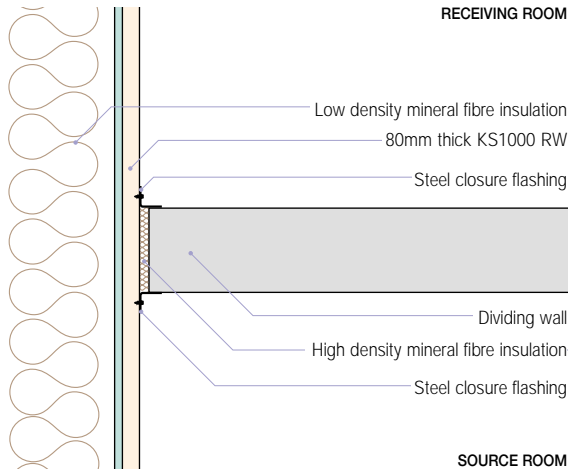

5F - KS1000 RW Insulated Roof & Wall Panel

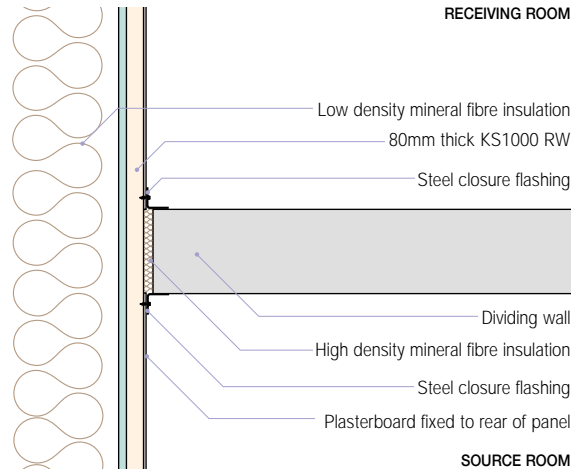

6F - KS1000 RW Insulated Roof & Wall Panel

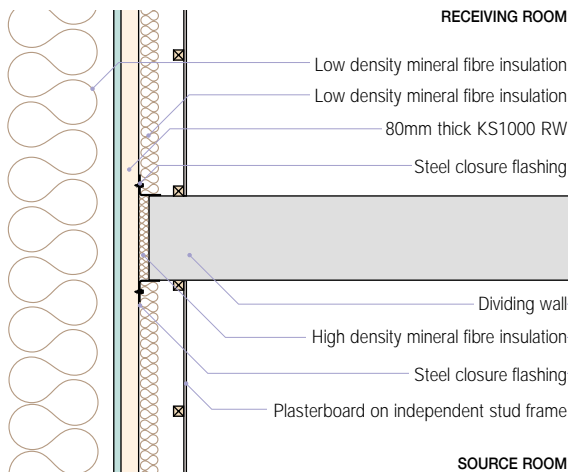

7F - KS1000 AWP Insulated Wall Panel

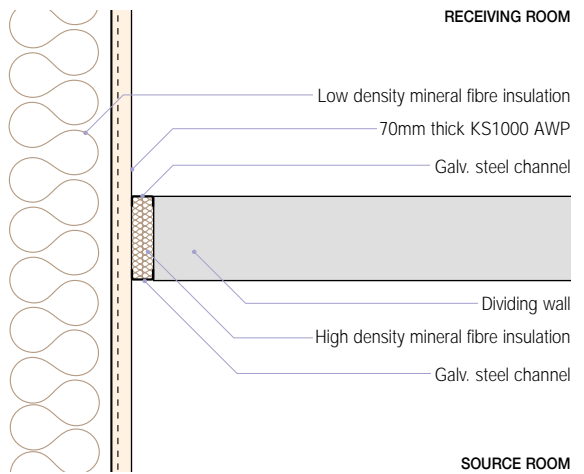

## Appendix C - Flanking Test Construction Details

8F - KS1000 AWP Insulated Wall Panel

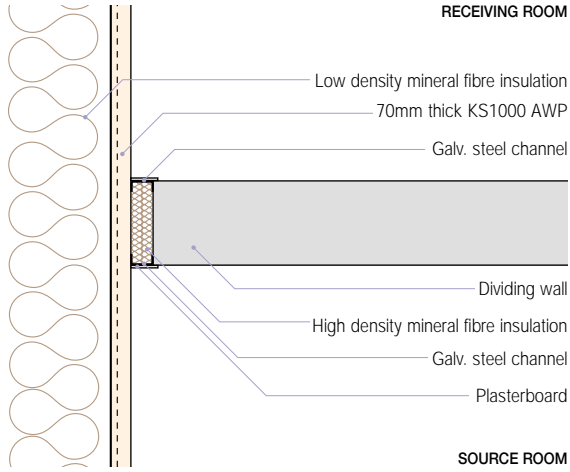

9F - KS1000 AWP Insulated Wall Panel

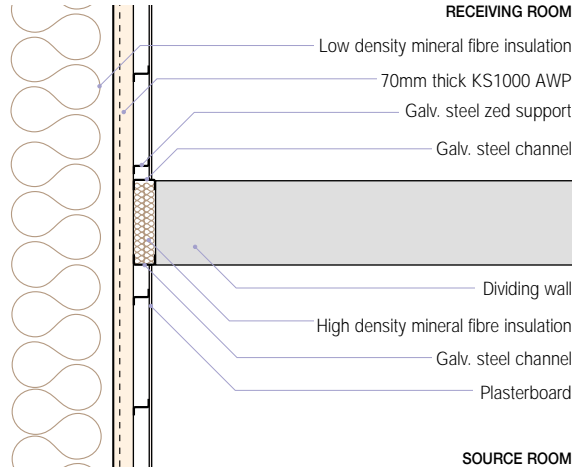

10F - KS1000 RW Insulated Roof & Wall Panel

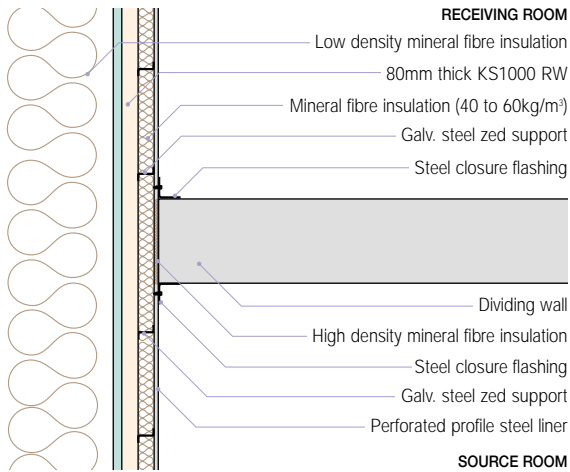

## Appendix D - Absorption Test Construction Details

### 1A - KS1000 RW (80) - Insulated Roof Panel

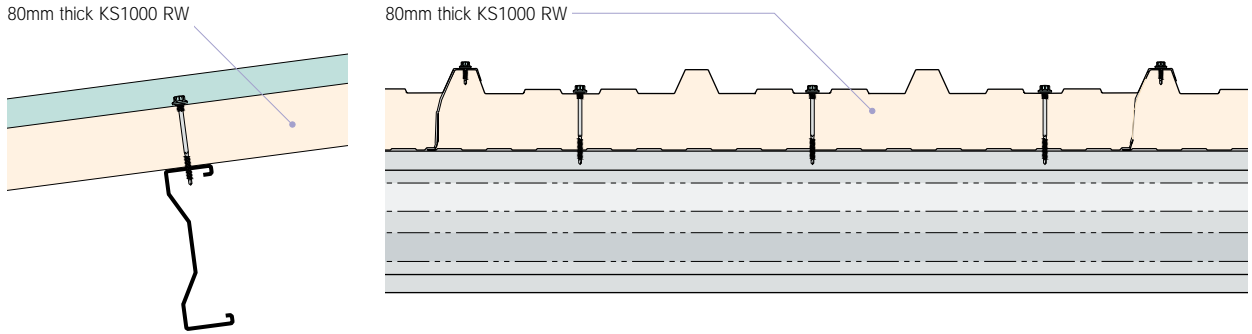

### 2A - KS1000 RW (80) - Insulated Roof Panel

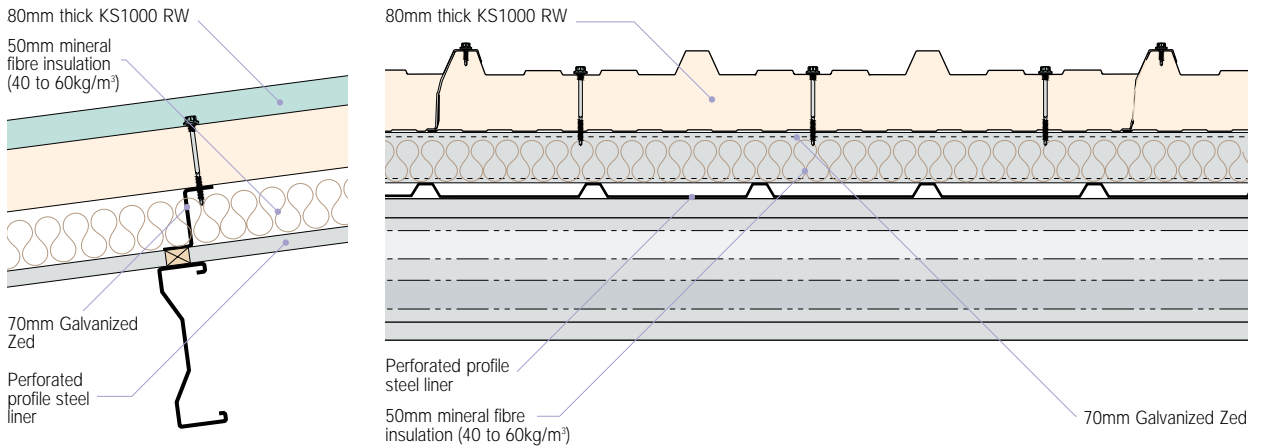

## Appendix E - Rain Noise Tests Construction Details

### 1RR - KS1000 RW (80) - Insulated Roof Panel

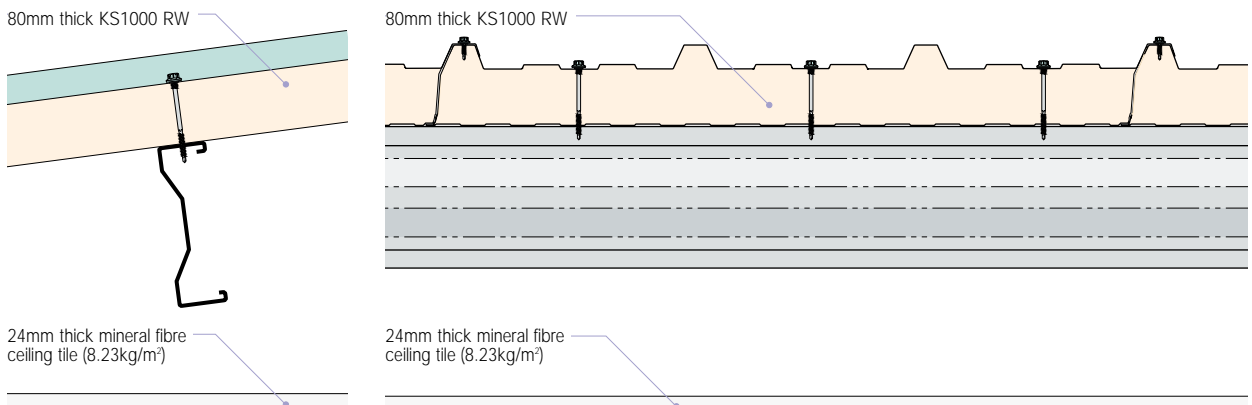

## Appendix E - Rain Noise Tests Construction Details

### 2RR - KS1000 RW (80) - Insulated Roof Panel

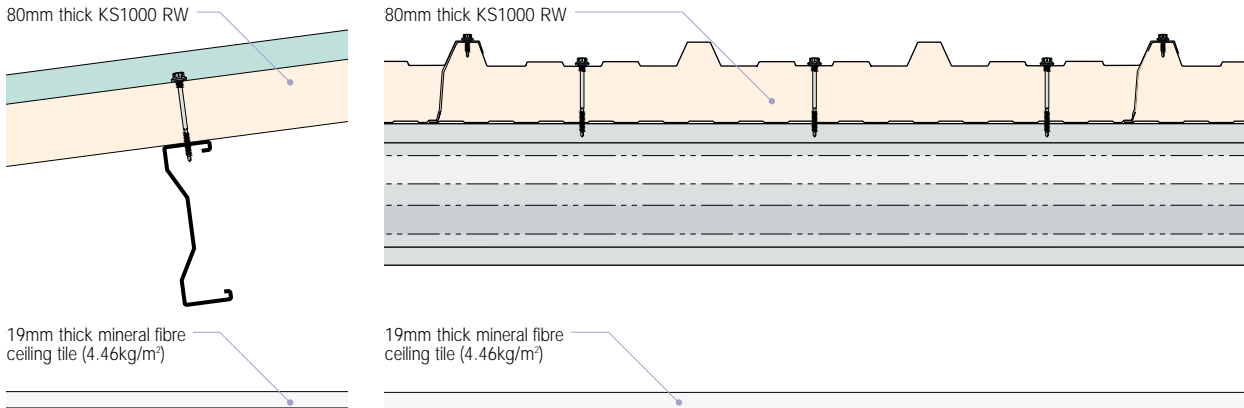

### 3RR - KS1000 RW (80) - Insulated Roof Panel

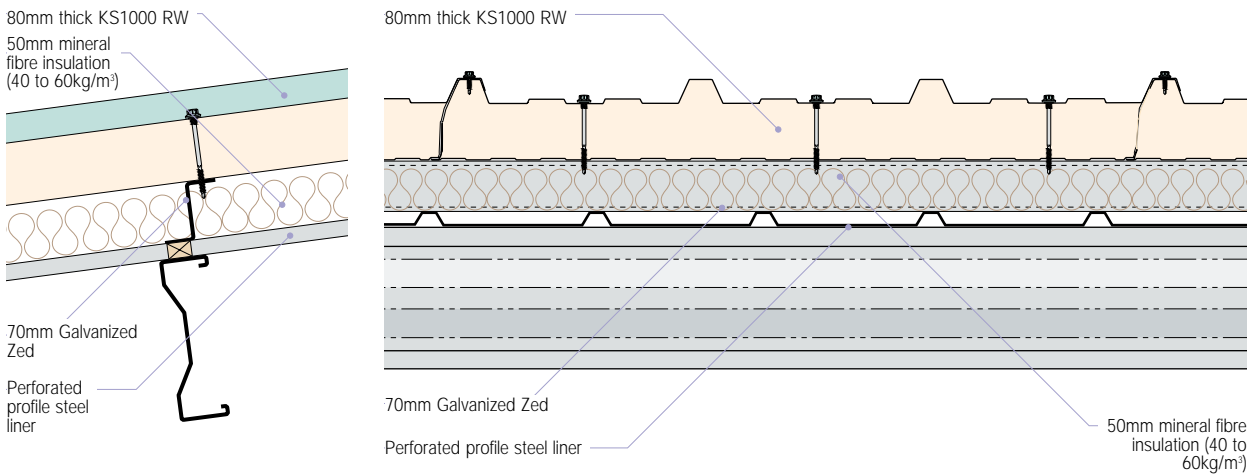

### 4RR - KS1000 TS (80) - Insulated Tile Support Panel

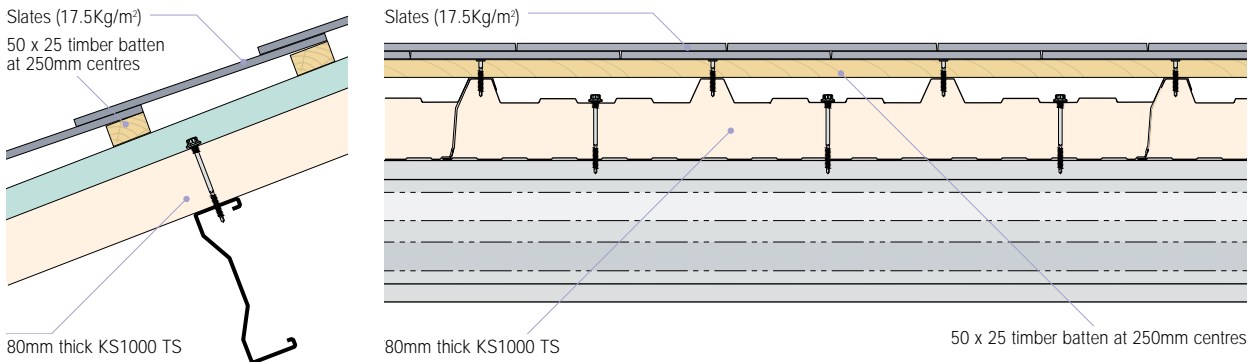

## Appendix F - Standard Flanking Construction Detail

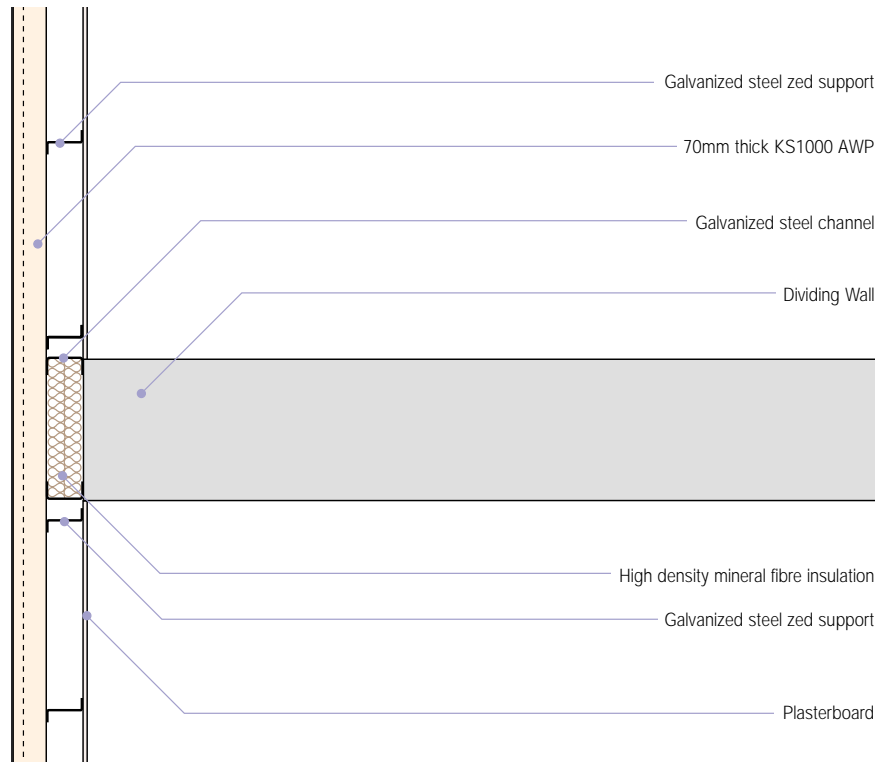

## Enhanced Flanking Construction Detail

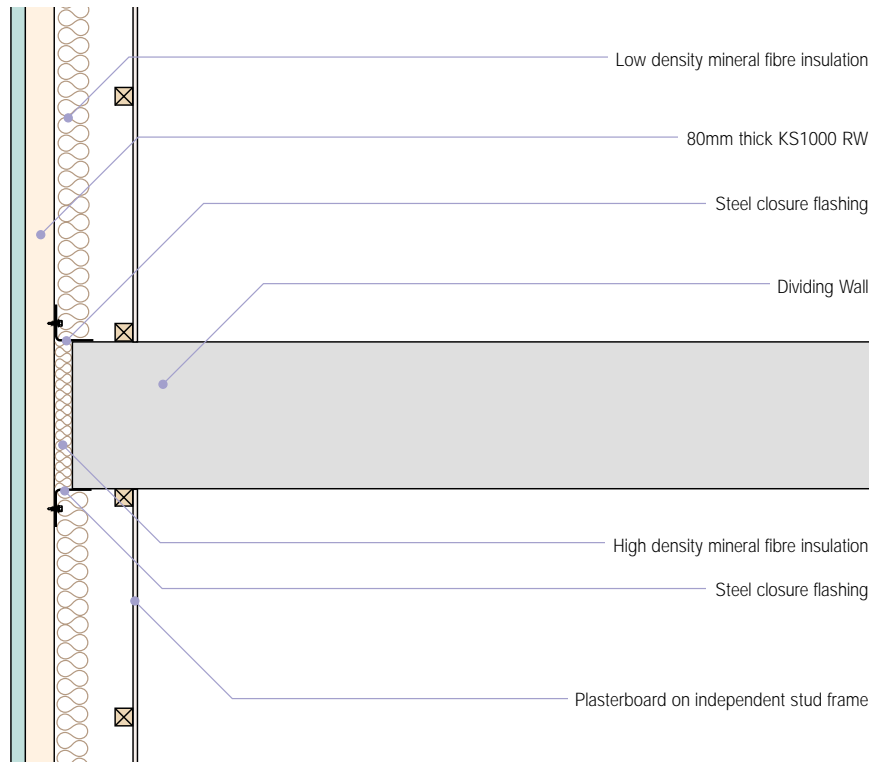

## Appendix G - Terminology

### Acoustic Measurement Parameter Definitions

dB

Decibel: a logarithmic scale applied to acoustic units such as sound pressure and sound power. Decibels are always the ratio between two numbers. Sound Pressure in Pascals becomes "Sound Pressure Level re  $2 \times 10^{-5}$  Pa" in decibels. Sound Power in watts becomes "Sound Power Level re  $10^{-12}$  W" in decibels. It is also used for sound reduction or sound insulation and is the ratio of the amount of sound energy incident upon a partition and the proportion of that energy which passes through the partition. The result is stated as a "decibel reduction".

dB(A)

A-weighting: This is an electronic filter which attenuates sound levels at some frequencies relative to the sound levels at other frequencies. The weighting is designed to produce the relative response of a human ear to sound at different frequencies. The A-weighted sound level is therefore a measure of the subjective loudness of sound rather than physical amplitude. A-weighting is used extensively and is denoted by the subscript A as in  $L_{A10}$ ,  $L_{Aeq}$  etc. (Levels given without the subscript A are linear sound levels without the A-weighting applied, e. g.  $L_{10}$ ,  $L_{eq}$  etc.).

$L_{Aeq,T}$

The "A" weighted equivalent continuous sound pressure level. This may be thought of as the "average" sound level over a given time "T". It is used for assessing noise from various sources: industrial and commercial premises, construction sites, railways and other intermittent noises.

$L_{A90,T}$

The "A" weighted sound pressure level that is exceeded for 90% of the time T. It reflects the quiet periods during that time and is often referred to as the "background noise level". It is used for setting noise emission limits for industrial and commercial premises.

$L_{Amax}$

The maximum "A" weighted sound pressure level during a given time on fast or slow response.

$L_{pA}$

The "A" weighted sound pressure Level. The sound pressure level is filtered through a standard frequency weighting known as A-weighting. This filter copies the frequency response of the human ear, so that the resulting sound level closely represents what people actually hear.

R

Is the sound reduction index of a construction element in octave or  $1/3$  octaves and can only be measured in a laboratory. There must be no flanking transmission.

R'

Is the sound reduction index of a construction element in octave or  $1/3$  octaves measured on site, and normally includes flanking transmission (ie where sound travels via paths other than straight through the element being tested, such as columns, ducts, along external walls, etc).

$R_w$

To get the weighted sound reduction index ( $R_w$ ) of a construction, the R values are measured in octave or  $1/3$  octave bands covering the range of 100Hz to 3150Hz. The curve is adjusted so that the unfavourable deviation (or shortfall of the actual measurements below this standard curve) averaged over all the octave or  $1/3$  octave bands is not greater than 2dB. The value of the curve at 500Hz is the  $R_w$ .

$R'_w$

The apparent sound reduction index, which is determined in exactly the same way as the  $R_w$ , but on site where there is likely to be some flanking transmission.

D

This is the "level difference". It is determined by placing a noise source in one room and measuring the noise levels in that room (the "source room") and an adjacent room (the "receiver room"). You calculate the level difference by simply deducting the "receiver" noise level (dB) from the "source" noise level (dB).

$D_w$

This is the weighted level difference. D is measured on site in octave or  $1/3$  octave bands covering the range of 100Hz to 3150Hz. The D values are compared to a standard weighting curve. The curve is adjusted so that the "unfavourable deviation" (or shortfall of the actual measurements below this standard curve) averaged over all the octave or  $1/3$  octave bands is not greater than 2dB. The  $D_w$  is then the value of the curve at 500Hz.

$D_{nw}$

This is the weighted normalised level difference. D is measured on site in octave or  $1/3$  octave bands covering the range of 100Hz to 3150Hz. As the level difference is affected by the area of the common wall/ floor and the volume of the receiving room, as well as the amount of absorption in the receiving room, in the case of the  $D_{nt,w}$ , the results are "normalised" by a mathematical correction to  $10m^2$  of absorption ( $D_n$ ). The same weighting curve as for  $D_w$  is used to obtain the single figure:  $D_{nw}$ .

## $D_{nT,w}$

This is the weighted standardised level difference.  $D$  is measured on site in octave or  $1/3$  octave bands covering the range of 100Hz to 3150Hz. As the level difference is affected by the area of the common wall/ floor and the volume of the receiving room, as well as the amount of absorption in the receiving room, in the case of the  $D_{nT,w}$ , the results are "standardised" by a mathematical correction a reverberation time, usually 0.5 seconds ( $D_{nT}$ ). The same weighting curve as for  $D_w$  is used to obtain a single figure:  $D_{nT,w}$ .

## $D_{nT(mf, max),w}$

This is the weighted BB93 standardised level difference corresponding to a Building Bulletin 93 reference value reverberation time in a receiving room. It is measured on site in accordance with BS EN ISO 140- 4: 1998.

## $D_{n,c}$

Suspended ceiling normalised level difference. This is the sound level difference between two rooms, separated by a suspended ceiling, normalised to a reference value of absorption in the receiving room (10m<sup>2</sup> for the Laboratory as specified in ISO 140- 9 : 1985). It is measured in  $1/3$  octave or octave frequency bands.

## $D_{n,c,w}$

Weighted suspended ceiling normalised level difference. This is a single number quantity representing the sound reduction between two rooms separated a suspended ceiling. It is obtained by applying specified weightings to the  $1/3$  octave band suspended ceiling normalised level differences in the frequency range 100Hz to 3150Hz.

## $C_{tr}$

Spectrum adaptation term: Value, in decibels, to be added to a single- number rating (e. g.  $R_w$ ) to take account of the characteristics of particular sound spectra.  $C_{tr}$  is calculated using an A- weighted urban traffic noise spectrum as defined in BS EN ISO 717- 1 : 1997.

## NR

Stands for Noise Rating. (It is NOT noise reduction). It is (e. g. NR30, NR35 etc.) a single number, which represents the sound level in a room and takes account of the frequency content of the noise. The lower the NR value, the quieter the room will be. It is mainly used for assessing noise from mechanical services systems. In leisure developments it is used as a standard for noise break- in to rooms from external noise sources such as traffic.

## NC

stands for Noise Criteria. It is very similar to NR but (e.g. NC30, NC35 etc.) uses slightly different frequency weightings.

## NRC

Stands for Noise Reduction Coefficient. The noise reduction coefficient of a material is the average, to the nearest multiple of 0.05, of the absorption coefficients at 250Hz, 500Hz, 1kHz and 2kHz.

## $\alpha$

Stands for Absorption Coefficient, which represents the proportion of incident sound energy arriving from all directions that is not reflected back into the room. It ranges between 0 and 1, where 0 is reflective and 1 is totally absorptive.

## $\alpha_w$

Stands for Weighted Absorption Coefficient. Single- number frequency dependent value which equals the value of the reference curve at 500Hz after shifting it as specified in EN ISO 11654 : 1997.

## $\alpha_p$

Stands for practical absorption factor. It is a frequency dependent value of sound absorption coefficient which is based on measurements in one- third- octave bands in accordance with ISO 354 and which is calculated in octave bands in accordance with EN ISO 11654 : 1997. It is the arithmetic mean of the three one- third- octave sound absorption coefficients within the octave being considered. The mean value is calculated to the second decimal place and rounded in steps of 0.05 up to a value of 1.0.

## Class X

Stands for the Absorption Class between 250 and 4kHz, as defined by EN ISO 11654. Class A is the best classification representing the highest level of absorption, and Class E offers to lowest classification.

## RT or $T_{60}$

Is Reverberation Time. It is a measure of the echoic nature of a room. It is normally measured in  $1/3$  octave or  $1/1$  octave bands by creating a loud noise and measuring the time it takes for that noise to decay by 60dB.

The longer the reverberation time, the more 'echoey' a room sounds. For dwellings, a reverberation time of 0.5 seconds or less is normal. Cinema auditoria will have reverberation times of 1.0 second or below when fitted out, but up to 9 seconds at shell completion. When designing acoustically sensitive areas such as concert halls or lecture theatres, it is necessary to design the room finishes to achieve optimum reverberation times. These will vary depending on the type of activity in the room and the room volume.

## $T_{mf}$

Stands for the arithmetic average of the reverberation times in the 500Hz, 1kHz and 2kHz octave bands, for the type of receiving room, as defined in Building Bulletin 93.

## $T_{mf,max}$

Stands for the maximum  $T_{mf}$  value in the range of reverberation time for the type of receiving room, as defined in Building Bulletin 93.

## References

Building Bulletin 93 (BB93), Acoustic Design of Schools - A Design Guide, DfES

Health Technical Memorandum 2045 (HTM), Acoustics, NHS Estates, 1996

British Standard 8233, Sound Insulation and Noise Reduction for Buildings - Code of Practice, BSi, 1999

British Standard 4142, Method for Rating Industrial Noise Affecting Mixed Residential and Industrial Areas, BSi, 1997

Noise Control at Work Regulations 2006 (Consultative Version), HSE, 2004

Approved Document E (2003 edition)

Building Regulations 2000

### Further reading

Noise Control in Building Services, Sound Research Laboratories, 1998, ISBN 0- 08- 034067- 9

# Kingspan Insulated Roof, Wall & Facade Systems

## Roof Systems

KS1000 RW  
Trapezoidal

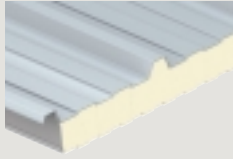

KS1000 SF  
Secret Fix



KS1000 TS  
Tile Support



KS500/1000 ZIP  
KingZIP®



KS1000 LP  
Lo-pitch

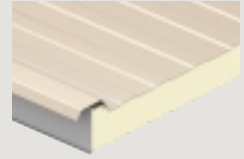

KS1000 CR  
Curved

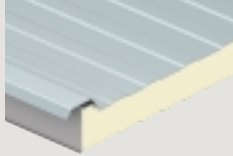

KS1000 RT  
Roof Tile



KS1000 XD  
X-dek®

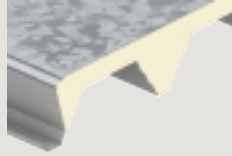

renders for LP and CR being amended at moment

## Wall & Facade Systems

KS600, 900  
& 1000  
Optimo™



KS600, 900  
& 1000 MR  
Micro-Rib



KS600, 900  
& 1000 EB  
Euro-Box



KS600, 900  
& 1000 FL-S  
Flat (Stucco)



KS1000 MR  
Facade System

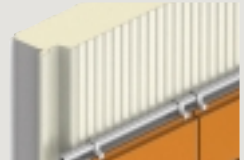

KS600, 900  
& 1000 MM  
Mini-Micro



KS600, 900  
& 1000 CX  
Convex

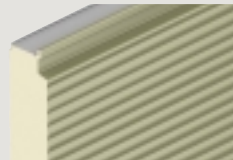

KS600, 900  
& 1000 WV  
Wave



KS600, 900  
& 1000 LS  
LongSpan

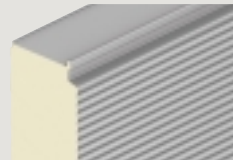

KS1000 RW  
Trapezoidal



## Controlled Environment Systems

KS1100 CS-Rib



KS1100 CS-FL



KS1100 CS-MR



**Kingspan Limited**

UK: Telephone: +44 (0) 1352 716100 Fax: +44 (0) 1352 710161 Email: [info@kingspanpanels.com](mailto:info@kingspanpanels.com)  
Ireland: Telephone: +353 (0) 42 96 98500 Fax: +353 (0) 42 96 98572 Email: [sales.ire@kingspanpanels.com](mailto:sales.ire@kingspanpanels.com)

Details for the following countries; Australia, Belgium, China, Czech Republic, Germany, Hungary, Netherlands, Poland, Singapore can be found by visiting our website [kingspanpanels.com](http://kingspanpanels.com) or our group website [kingspan.com](http://kingspan.com)